



Power Lite (Plus) Wiring and Settings Examples for models:

L051100-A, L051100-A1, L051100-B, L051100-D

Ver. 1.17

Click for the corresponding section:



No inverter communication (open-loop)



CAN inverter communication (closed-loop)





Table of Contents

Introduction	3
Battery Communication	3
Power Wiring	4
General Battery Quantities	4
Wiring Legend	5
Battery Firmware Overview	6
Deye	7
Goodwe	11
Growatt	14
Luxpower	17
Megarevo	20
Phocos (Open-Loop)	24
SAJ	27
SMA	30
Sofar	33
Sol-Ark	36
Solis	40
Solplanet	44
Steca (Open-Loop)	48
Studer Innotec	51
Victron Energy	56
Voltronic Power (Open-Loop)	59
Voltronic Power (Closed-Loop)	62

Introduction

This document is intended to show examples of how to wire UZ Energy batteries with photovoltaic hybrid inverters, as well as how to setup the inverters. All installations must be performed by trained electricians and UZ Energy bears no responsibility for incorrect installation or lack of adherence to local electrical regulations. Make sure to respect all safety indications from the UZ Energy battery manual for your particular battery model.

These examples show wiring and bus bars of the main inverter to battery connections, battery management system data wiring, as well as mandatory DC breakers. Other connections such as AC or photovoltaic (PV) connections are intentionally omitted, refer to the inverter manuals for more details. Additional equipment may be required for your installation. These examples apply to the following UZ Energy battery models (see [Battery Communication](#) for differences in wiring between models):

- All Power Lite series (L051100-A, L051100-A1, L051100-B and L051100-D)
- All Power Lite Plus series

All examples apply to 51.2 Vdc nominal battery voltage systems only.

Any examples labeled “open-loop” refer to setups without digital communication between the inverters and the batteries. While communication with the inverter is not required, it brings advantages in that the inverter can react to warnings coming from the battery management system (BMS) that is integrated in each individual battery. The safety of the batteries is ensured in either case via the protective BMS functions.

Any inverter images and manufacturer logos used in this document are for illustrative purposes only, their copyright remains with the respective inverter manufacturers.

Battery Communication

The Power Lite (Plus) series batteries can communicate with inverters via a CAN bus port. This document outlines with which inverters the CAN communication is compatible (if available) and what the pinout of the connectors is in the inverter-specific sections. The batteries’ CAN port has the following relevant pinout from the perspective of looking on the RJ45 connector on the battery front face:

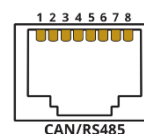

Pin	1	2	3	4	5	6	7	8
Function	CAN-H	RS485-A	RS485-B	NC	CAN-L	RS485-B	RS485-A	GND

Note: “NC” means not connected.

Warning: Only connect to the CAN-H, CAN-L and GND/ground pins (only if GND is mentioned in the pin-out of the various inverters) and **leave all other pins disconnected** for CAN communication. Some inverters have high voltages on some of their pins that could damage the battery and for some inverters connecting the GND/ground wire is not recommended. Some pins are also reserved by the inverter for synchronization or other functions, which could be disrupted if connected to. Damage to the battery or inverter by incorrect wiring is **not covered under warranty**.

Please note there are differences for the communication wiring depending on the Power Lite model:

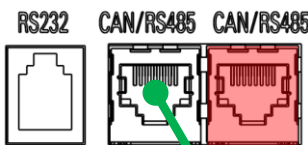
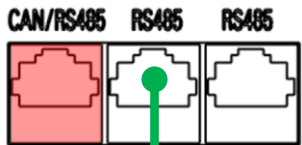
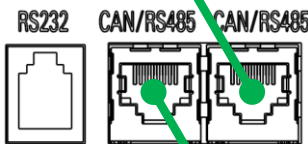
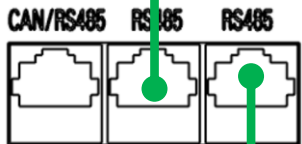
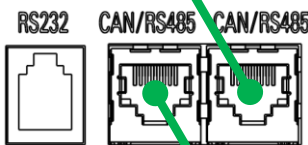
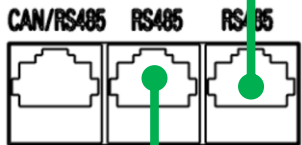
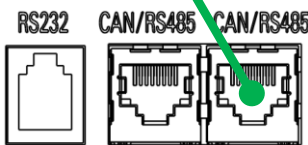
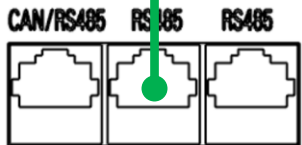
Battery model	L051100-A	L051100-A1, L051100-B and L051100-D
Connection Socket from Master Battery to Inverter (except open-loop systems) marked Red		
Connection from Master to Slave Batteries with cable kits available from UZ Energy marked Green here (except <u>Voltronic Power (Closed-Loop)</u>)		
		
		

Power Wiring

The maximum continuous current per battery and power connector is 100 Adc. As the total battery current for parallel batteries is added at the common positive and negative terminals connecting to the inverter(s), a maximum of 2 batteries may be used without busbars so as not to exceed the 100 Adc continuous rating (each battery can supply 50 Adc continuous). For any number of batteries above 2, busbars are required, as well as one 100 ~ 125 Adc breaker per battery, unless the connected inverter(s) are unable to charge and discharge with more than 100 Adc continuous.

The following diagrams for various inverters typically show an example without busbars and therefore 2 batteries and a single breaker. Further diagrams show examples with 3 batteries, busbars and breakers and can be applied for systems with 3 or more batteries (for more than 100 Adc continuous charge and/or discharge current) in the same fashion.

General Battery Quantities

As for all battery technologies, the permitted charge and discharge current and quantity of batteries must be taken into account for a balanced system. The battery quantities recommended for the various inverter models below are to achieve full power (up to the limits of the inverter) for AC loads in situations where no PV and no AC source (such as the grid) are available, so that all power must be sourced from the battery. Using fewer batteries than the recommended values typically is possible but may limit the available AC power in the scenario described above.

To better understand the effect of using less than the recommended battery quantity, here is an example. A single Power Lite is used with an inverter capable of delivering 3 kW to loads when no AC source or PV is present. Because a single battery can sustain 50 A continuous discharge current, the available AC load power will be: battery voltage x 50 Adc x inverter efficiency. Please note that by inverter efficiency, we are referring to the efficiency of the battery (DC) to the AC output (AC conversion) in percent. Assuming an inverter efficiency of 95% and a battery voltage of 50 Vdc, this would make 50 Vdc x 50 Adc x 95% = 2375 W available for AC loads when sourcing only from the battery. We choose 50 Vdc as the battery voltage because it is more conservative than the nominal 51.2 Vdc and is very roughly equivalent to a depth

of discharge of 80%, representing “realistic worst case” scenario. Please make sure to also set the maximum inverter charge and discharge current to an appropriate value, depending on the actual number of batteries used.

Here is the example above with one battery and a 3 kW inverter (less than recommended battery quantity):

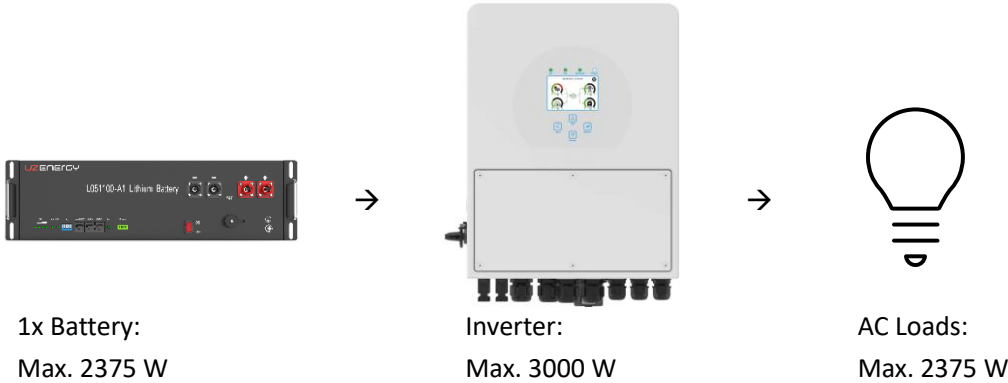

- One battery alone (when no PV or AC source is present) can conservatively deliver up to 2375 W
- Even though the inverter is capable of 3000 W, it is bottlenecked by the battery to 2375 W max.
- The bottleneck, here the battery, determines the max. AC load power at 2375 W

Here is the example above with two batteries and a 3 kW inverter (min. recommended battery quantity):

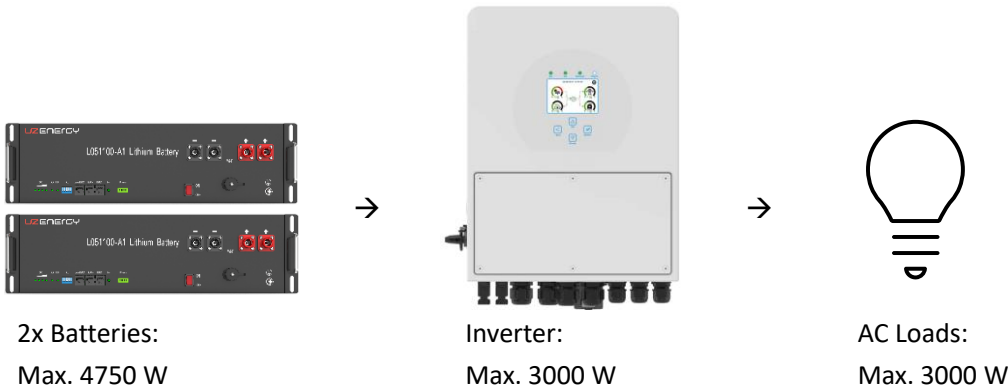

- Two batteries (when no PV or AC source is present) can conservatively deliver up to 2375 W per battery x 2 batteries = 4750 W total
- The inverter is capable of 3000 W, this time the inverter is the bottleneck
- The bottleneck, here the inverter, determines the max. AC load power at 3000 W

Wiring Legend

This legend applies to all wiring examples.

DC Power Negative (-)

DC Power Positive (+)

Ground

CAN (between battery Master and inverter) & RS-485 (between Master and Slave batteries, included with the batteries) Communication Wiring: see the CAN Communication Pinout sections of the various inverters.

Battery Firmware Overview

This table summarises the inverter models and the corresponding Power Lite battery firmware required for those inverters that need special battery firmware. All inverters not listed function with the standard battery firmware, the latest version can be downloaded [here](#).

Inverter Model	Inverter Firmware	L051100-A Firmware	L051100-A1, L051100-B and L051100-D Firmware
All brands in this document except SMA, Victron and Voltronic Power (Closed-Loop)			
	See Inverter Firmware Version and download from inverter manufacturer as necessary.	Download here <ul style="list-style-type: none"> General Version (excluding SMA, Victron and Voltronic Power inverters) <ul style="list-style-type: none"> For L051100-A (Old) <ul style="list-style-type: none"> LM-M01A-YZ107-21.Q2.15-221221.bin 76.1KB For L051100-A (New) <ul style="list-style-type: none"> LM-M01S-YZ107-21.Z0.03-230105.bin 86.8KB For L051100-A1 / -B / -D <ul style="list-style-type: none"> LM-M01S-YZ109-21.Z0.18-230325.bin 87.8KB or <ul style="list-style-type: none"> General Version (excluding SMA, Victron and Voltronic Power inverters) <ul style="list-style-type: none"> For L051100-A (Old) <ul style="list-style-type: none"> LM-M01A-YZ107-21.Q2.15-221221.bin 76.1KB For L051100-A (New) <ul style="list-style-type: none"> LM-M01S-YZ107-21.Z0.03-230105.bin 86.8KB For L051100-A1 / -B / -D <ul style="list-style-type: none"> LM-M01S-YZ109-21.Z0.18-230325.bin 87.8KB 	Download here <ul style="list-style-type: none"> General Version (excluding SMA, Victron and Voltronic Power inverters) <ul style="list-style-type: none"> For L051100-A (Old) <ul style="list-style-type: none"> LM-M01A-YZ107-21.Q2.15-221221.bin 76.1KB For L051100-A (New) <ul style="list-style-type: none"> LM-M01S-YZ107-21.Z0.03-230105.bin 86.8KB For L051100-A1 / -B / -D <ul style="list-style-type: none"> LM-M01S-YZ109-21.Z0.18-230325.bin 87.8KB
SMA			
All compatible SMA inverters	See Inverter Firmware Version and download from inverter manufacturer as necessary.	Not compatible	Download here <ul style="list-style-type: none"> Special Version (for SMA Sunny Island, approved by SMA) <ul style="list-style-type: none"> For L051100-A1 / -B / -D <ul style="list-style-type: none"> LM-M01S-YZ109S-21.Z9.04-230525.bin 90.4KB
Victron			
All compatible Victron inverters	See Inverter Firmware Version and download from inverter manufacturer as necessary.	Not compatible	Download here <ul style="list-style-type: none"> Special Version (for Victron inverters) <ul style="list-style-type: none"> For L051100-A1 / -B / -D <ul style="list-style-type: none"> LM-M01S-YZ109S-21.Z9.04-230302.bin 90.3KB
Voltronic Power (Closed-Loop with CAN Communication)			
Axpert King Rack 5K (48 Vdc)	Axpert King Rack	Not compatible	Download here <ul style="list-style-type: none"> Special Version (for Voltronic Power inverters) <ul style="list-style-type: none"> For L051100-A1 / -B / -D <ul style="list-style-type: none"> LM-M01S-YZ109V-21.Z0.17-220901.bin 88.6KB
Axpert King 5K (48 Vdc)	Axpert King	Not compatible	Download here <ul style="list-style-type: none"> Special Version (for Voltronic Power inverters) <ul style="list-style-type: none"> For L051100-A1 / -B / -D <ul style="list-style-type: none"> LM-M01S-YZ109V-21.Z0.17-220901.bin 88.6KB
Other models with CAN port	Not yet available	Not compatible	Download here <ul style="list-style-type: none"> Special Version (for Voltronic Power inverters) <ul style="list-style-type: none"> For L051100-A1 / -B / -D <ul style="list-style-type: none"> LM-M01S-YZ109V-21.Z0.17-220901.bin 88.6KB

Deye

These examples apply to the following Deye inverters:

- SUN-SG01LP1 series ($\leq 8k$)
- SUN-SG03LP1 series

and show L051100-A Power Lite batteries. See [Battery Communication](#) for details regarding -A1, -B and -D Power Lite batteries.

Inverter Firmware Version

The minimum firmware requirement is:

- For inverter model: SUN-8K-SG01LP1-EU
Firmware: 1870
- For inverter model: GSL-H-7.6K-US-B
Firmware: 5976/5209

CAN Communication Pinout

Deye inverters have the following relevant CAN pinout:

Pin	1	2	3	4	5	6	7	8
Function		GND		CAN-H	CAN-L			

See section [Battery Communication](#) for the corresponding pins on the battery.

Cable Kit

Inverter Model	Cable Kit	Communication Cable	Power Cables (x2)
SUN-SG01LP1 series ($\leq 8k$)	CA03	1.5m, RJ45→RJ45	1.5m, Hot-plug→Ring terminal M8
SUN-SG03LP1 series	CA04	1.5m, RJ45→RJ45	1.5m, Hot-plug→Ring terminal M10

Inverter Settings

Set the battery type to “Lithium” and ensure the battery capacity corresponds to the number of Power Lite batteries used x 100 Ah. Also check the “Max A Charge” and “Max A Discharge” are set to the number of Power Lite batteries used x 50 A. Depending on the inverter and number of batteries used, sometimes only a lower number may be entered for the charge / discharge current, this is a limitation of the inverter and not an issue. Ensure “Activate Battery” is checked. This example shows a configuration for 3 batteries.

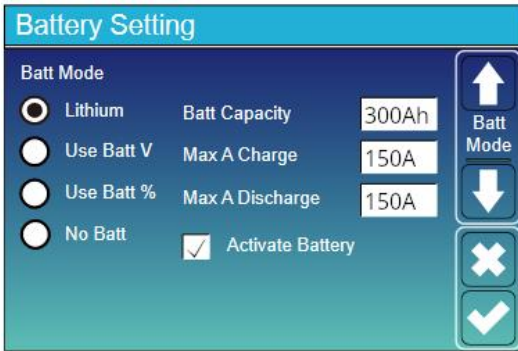

Finally, also check that the “Lithium Mode” is set to “00”:

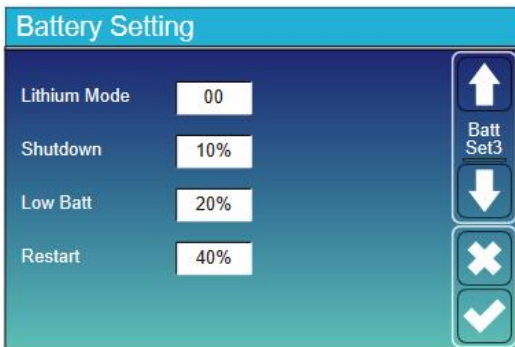

Battery Quantities

The following quantities of batteries are recommended (see section [General Battery Quantities](#) for details), while of course more batteries can be used.

Inverter Model	AC Phases	AC Power Cont.	Max. Charge / Discharge Current Cont.	Power Lite Recommended Battery Qty.
SUN-3.6K-SG03LP1 SUN-3.6K-SG05LP1	1	3,600 W	90 A	2
SUN-5K-SG01LP1 SUN-5K-SG03LP1 SUN-5K-SG05LP1	1	5,000 W	120 A	3
SUN-6K-SG01LP1 SUN-6K-SG03LP1 SUN-6K-SG05LP1	1	6,000 W	135 A	3
SUN-7.6K-SG05LP1	1	7,600 W	190 A	4
SUN-8K-SG01LP1 SUN-8K-SG05LP1	1	8,000 W	190 A	4
SUN-5K-SG04LP3	3	5,000 W	120 A	3
SUN-6K-SG04LP3	3	6,000 W	150 A	3
SUN-8K-SG04LP3	3	8,000 W	190 A	4
SUN-10K-SG04LP3	3	10,000 W	210 A	4
SUN-12K-SG04LP3	3	12,000 W	240 A	5

Example for up to 2 Batteries

No bus bar required, and a single battery breaker is sufficient.

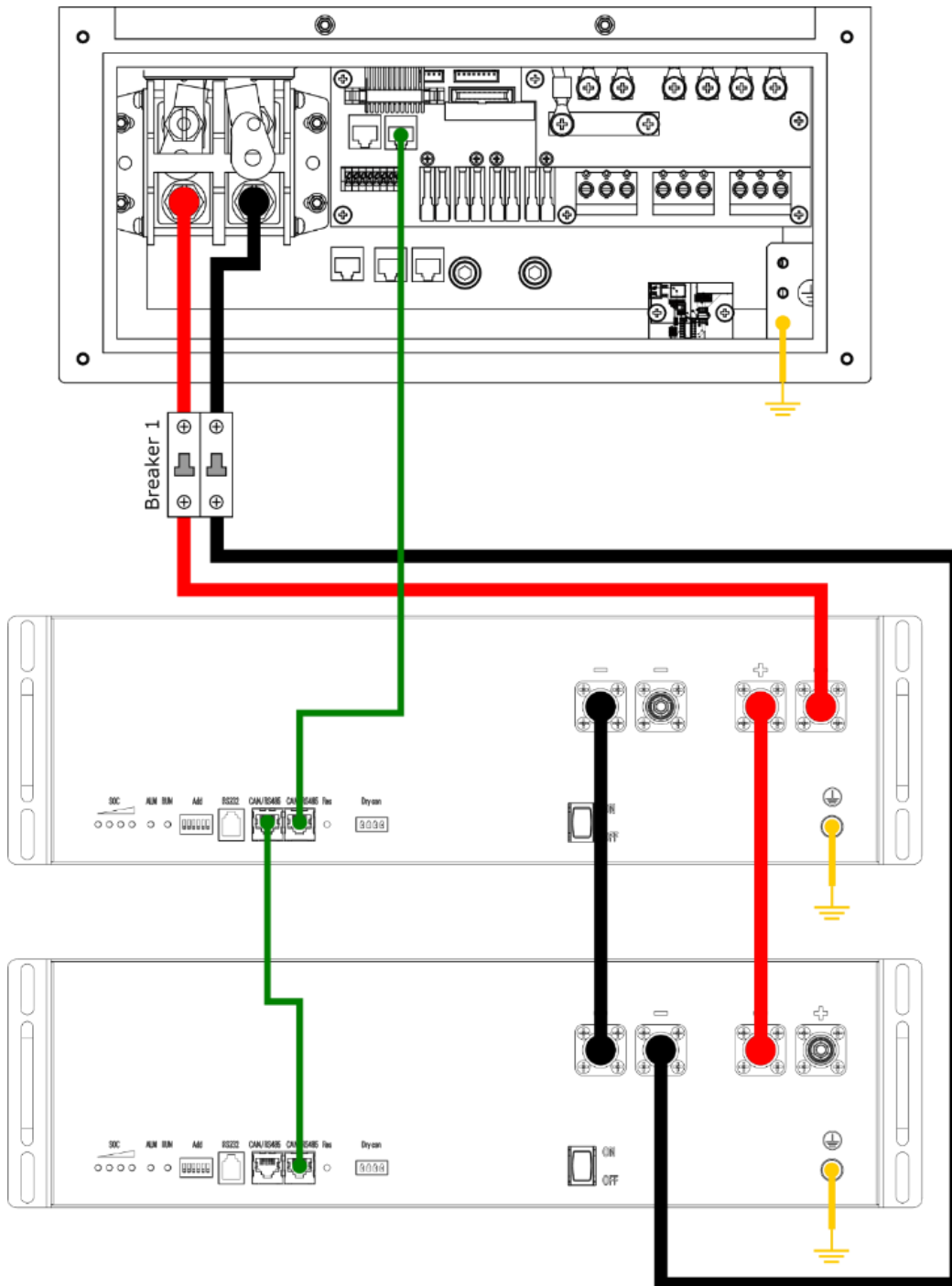

Example for 3 and more Batteries

Bus bar is required and a battery breaker per battery is recommended.

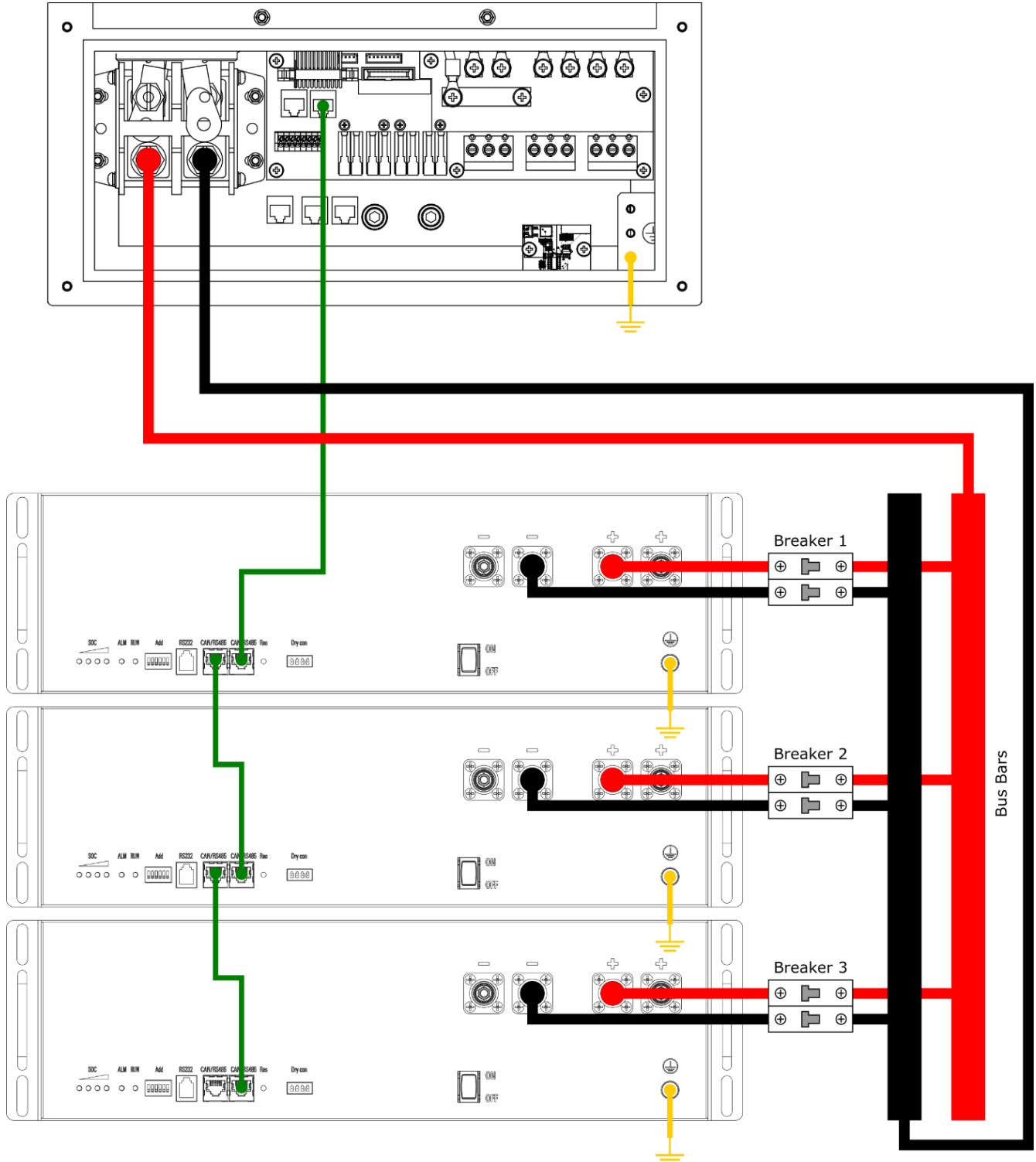

Goodwe

These examples apply to the following Goodwe inverters:

- GW-BP/SBP series
- GW-ES/EM series

and show L051100-A Power Lite batteries. See [Battery Communication](#) for details regarding -A1, -B and -D Power Lite batteries.

Inverter Firmware Version

The minimum firmware requirement is:

- For inverter model: GW5048D-ES
Firmware: 2121C

CAN Communication Pinout

Goodwe inverters have the following relevant CAN pinout:

Pin	1	2	3	4	5	6	7	8
Function				CAN-H	CAN-L			

See section [Battery Communication](#) for the corresponding pins on the battery.

Inverter Settings

Set the battery type to “UZENERGY” → “L051100-A1” if using a single L051100-A/A1/B/D battery, or “L051100-A2+” if using more than one L051100-A/A1/B/D battery. This example shows a configuration for ≥ 2 batteries:

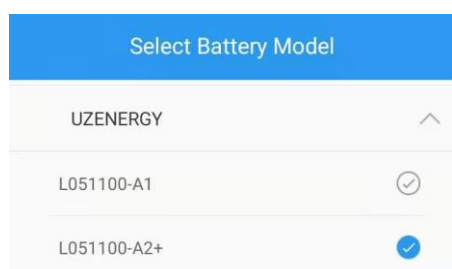

Battery Quantities

The following quantities of batteries are recommended (see section General Battery Quantities for details), while of course more batteries can be used.

Inverter Model	AC Phases	AC Power Cont.	Max. Charge / Discharge Current Cont.	Power Lite Recommended Battery Qty.
GW3600S-BP	1	3,600 W	75 A	2
GW5000S-BP	1	5,000 W	100 A	2
GW3648D-ES	1	3,680 W	75 A	2
GW5048D-ES	1	5,000 W	100 A	2
GW3048-EM	1	3,000 W	50 A	1
GW3648-EM	1	3,680 W	50 A	1
GW5048-EM	1	5,000 W	50 A	1

Example for up to 2 Batteries

No bus bar required, and a single battery breaker is sufficient.

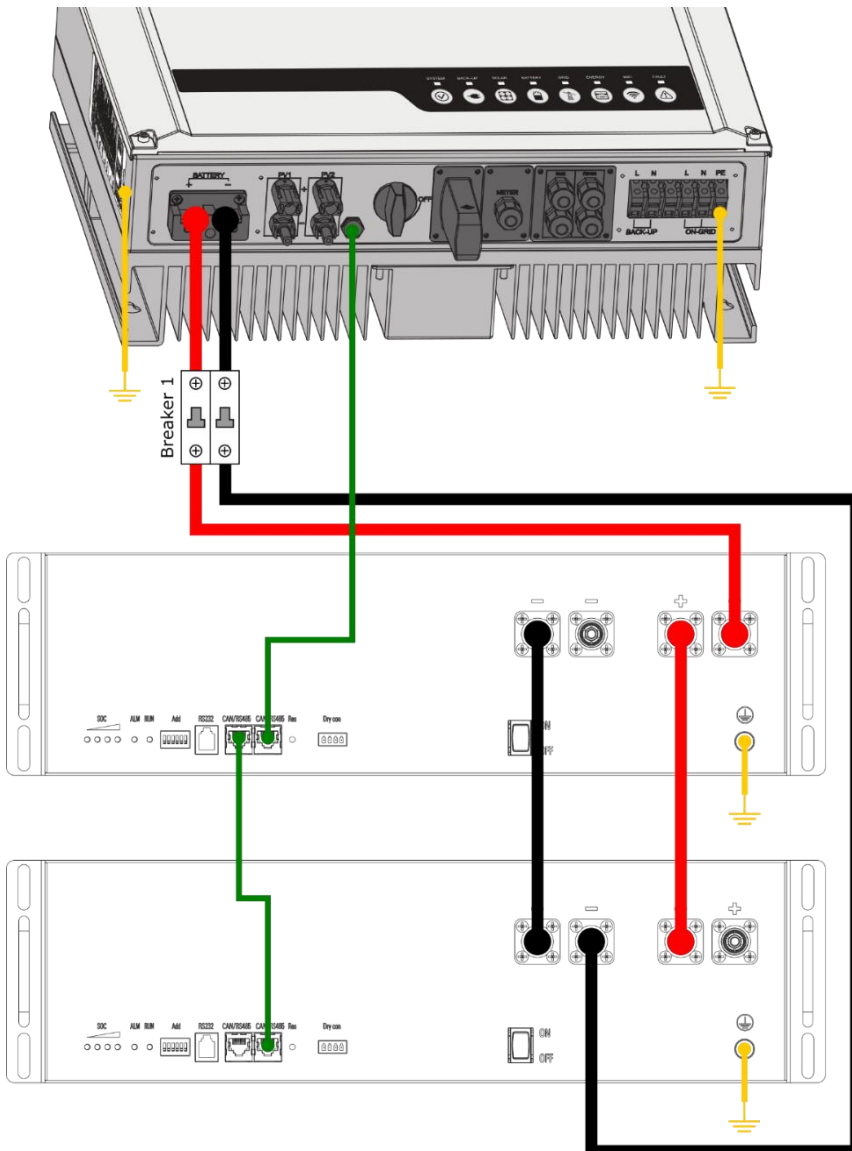

Example for 3 and more Batteries

Bus bar is required and a battery breaker per battery is recommended.

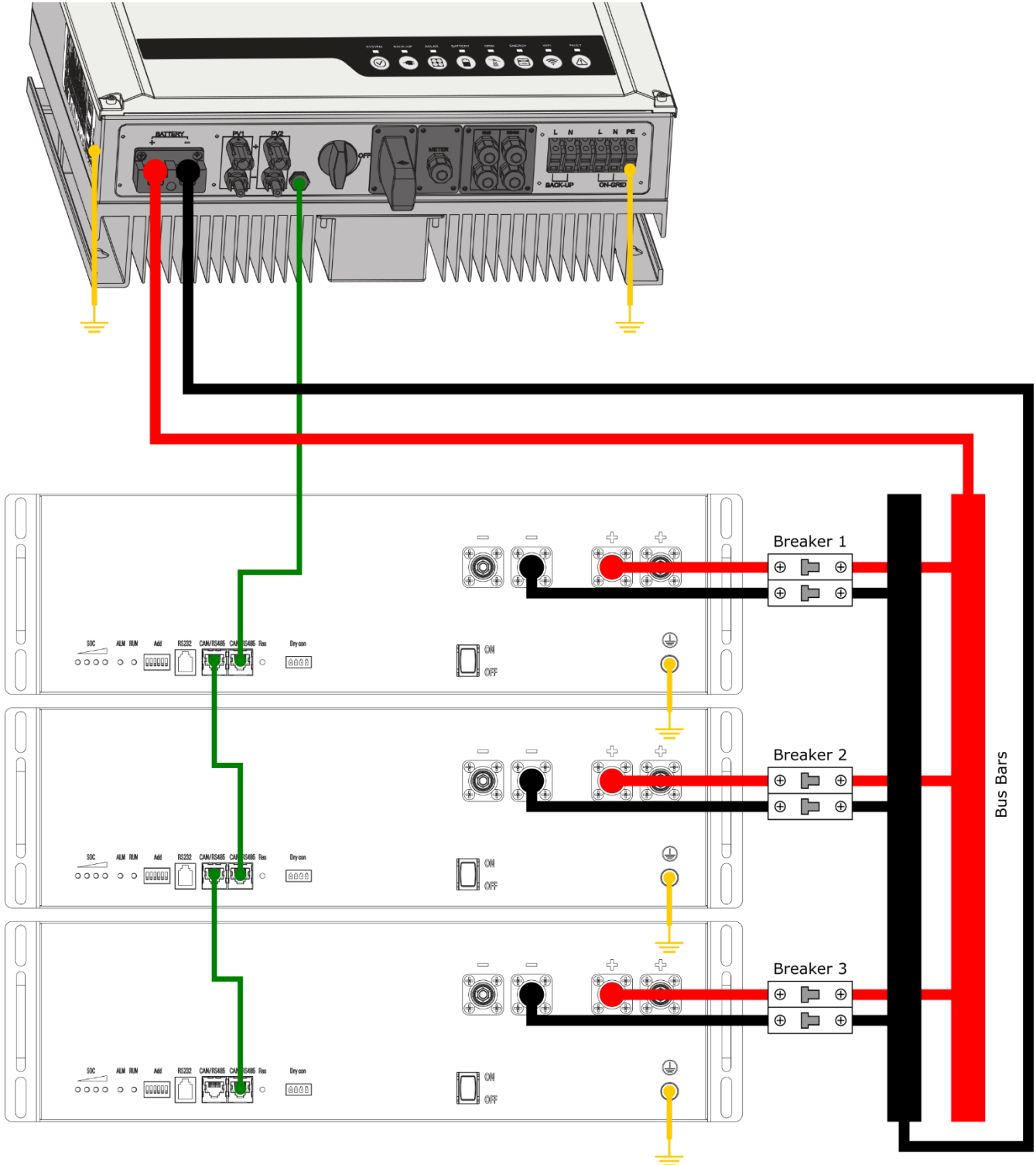

Growatt

These examples apply to the following Growatt inverters:

- SPH 6000
- SPH 5000TL

and show L051100-A Power Lite batteries. See [Battery Communication](#) for details regarding -A1, -B and -D Power Lite batteries.

Inverter Firmware Version

The minimum firmware requirement is:

- For inverter model: SPH5000TL BL-UP
Firmware: RA1.0

CAN Communication Pinout

Growatt inverters have the following relevant CAN pinout:

Pin	1	2	3	4	5	6	7	8
Function		GND		CAN-H	CAN-L			

See section [Battery Communication](#) for the corresponding pins on the battery.

Battery Quantities

The following quantities of batteries are recommended (see section [General Battery Quantities](#) for details), while of course more batteries can be used.

Inverter Model	AC Phases	AC Power Cont.	Max. Charge / Discharge Power Cont.	Power Lite Recommended Battery Qty.
SPH 5000	1	5,000 W	3000 W	2
SPH 6000	1	6,000 W	3000 W	2

Example for up to 2 Batteries

No bus bar required, and a single battery breaker is sufficient.

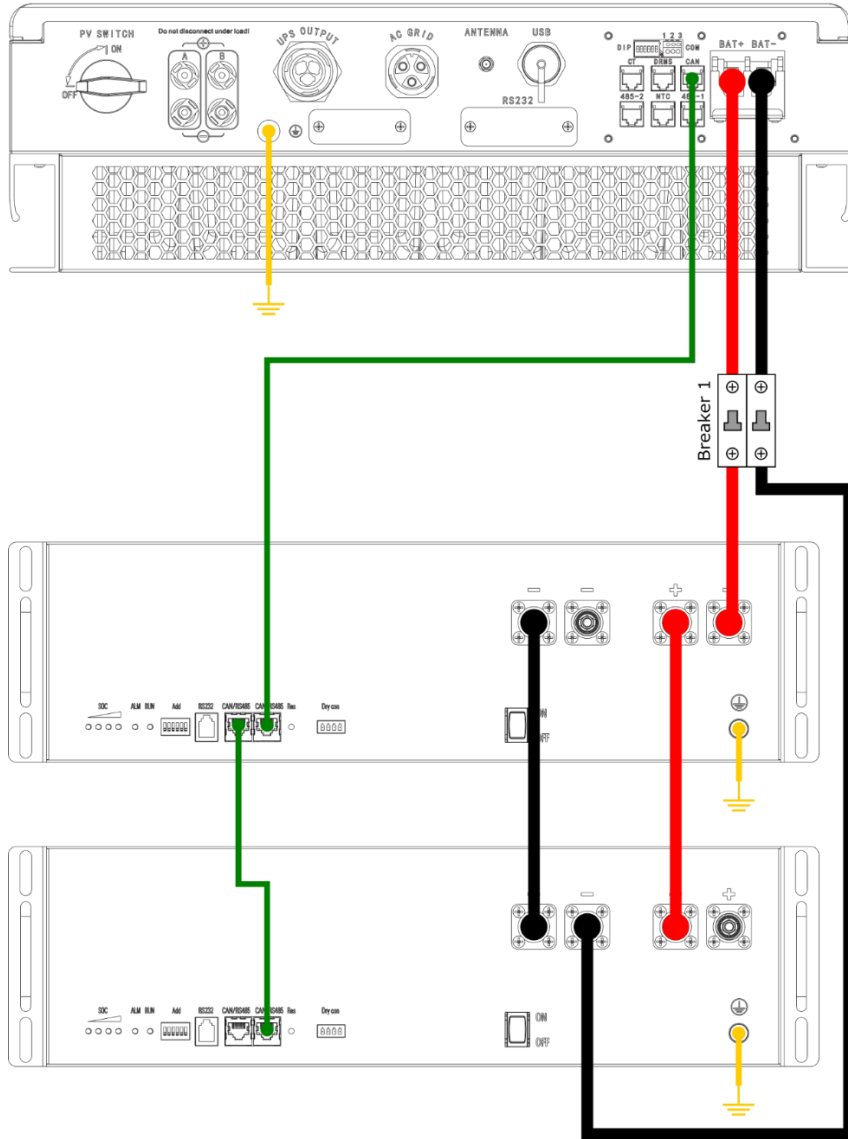

Example for 3 and more Batteries

Bus bar is required and a battery breaker per battery is recommended.

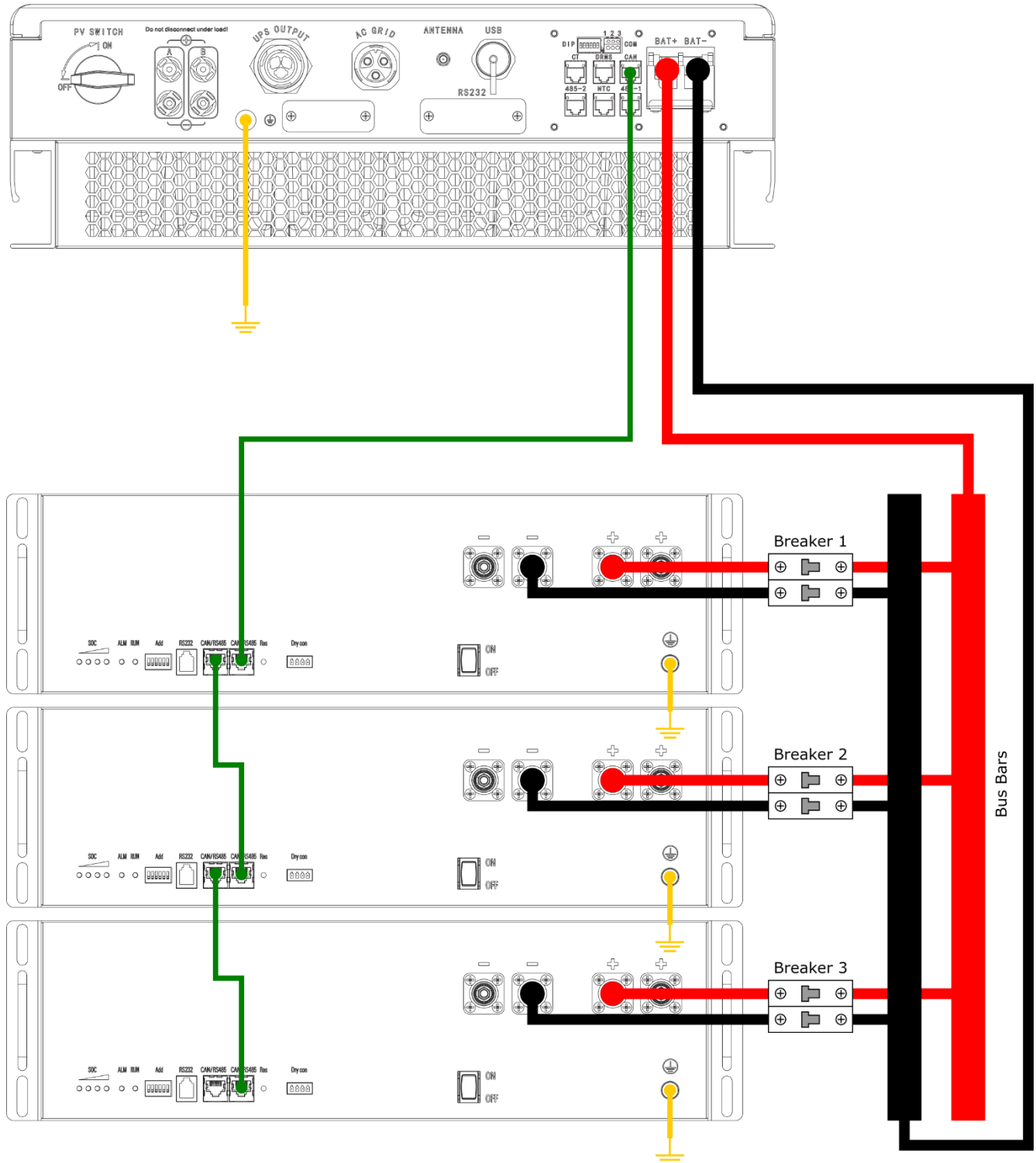

Luxpower

These examples apply to the following Luxpower inverters:

- LXP Hybrid/ACS series

and show L051100-A Power Lite batteries. See [Battery Communication](#) for details regarding -A1, -B and -D Power Lite batteries.

Inverter Firmware Version

The minimum firmware requirement is:

- For inverter model: LXP-3.6K Hybrid
Firmware: AAAA-1719

CAN Communication Pinout

Luxpower inverters have the following relevant CAN pinout:

Pin	1	2	3	4	5	6	7	8
Function			CAN-L	CAN-H				GND

See section [Battery Communication](#) for the corresponding pins on the battery.

Battery Quantities

The following quantities of batteries are recommended (see section [General Battery Quantities](#) for details), while of course more batteries can be used.

Inverter Model	AC Phases	AC Power Cont.	Max. Charge / Discharge Current Cont.	Power Lite Recommended Battery Qty.
LXP-3K Hybrid	1	3,000 W	66 A	2
LXP-3.6K Hybrid	1	3,600 W	80 A	2
LXP-4K Hybrid	1	4,000 W	80 A	2
LXP-4.6K Hybrid	1	4,600 W	80 A	2
LXP-5K Hybrid	1	5,000 W	80 A	2
LXP-6K Hybrid	1	6,000 W	80 A	2
LXP 3600 ACS	1	3,600 W	70 A	2

Example for up to 2 Batteries

No bus bar required, and a single battery breaker is sufficient.

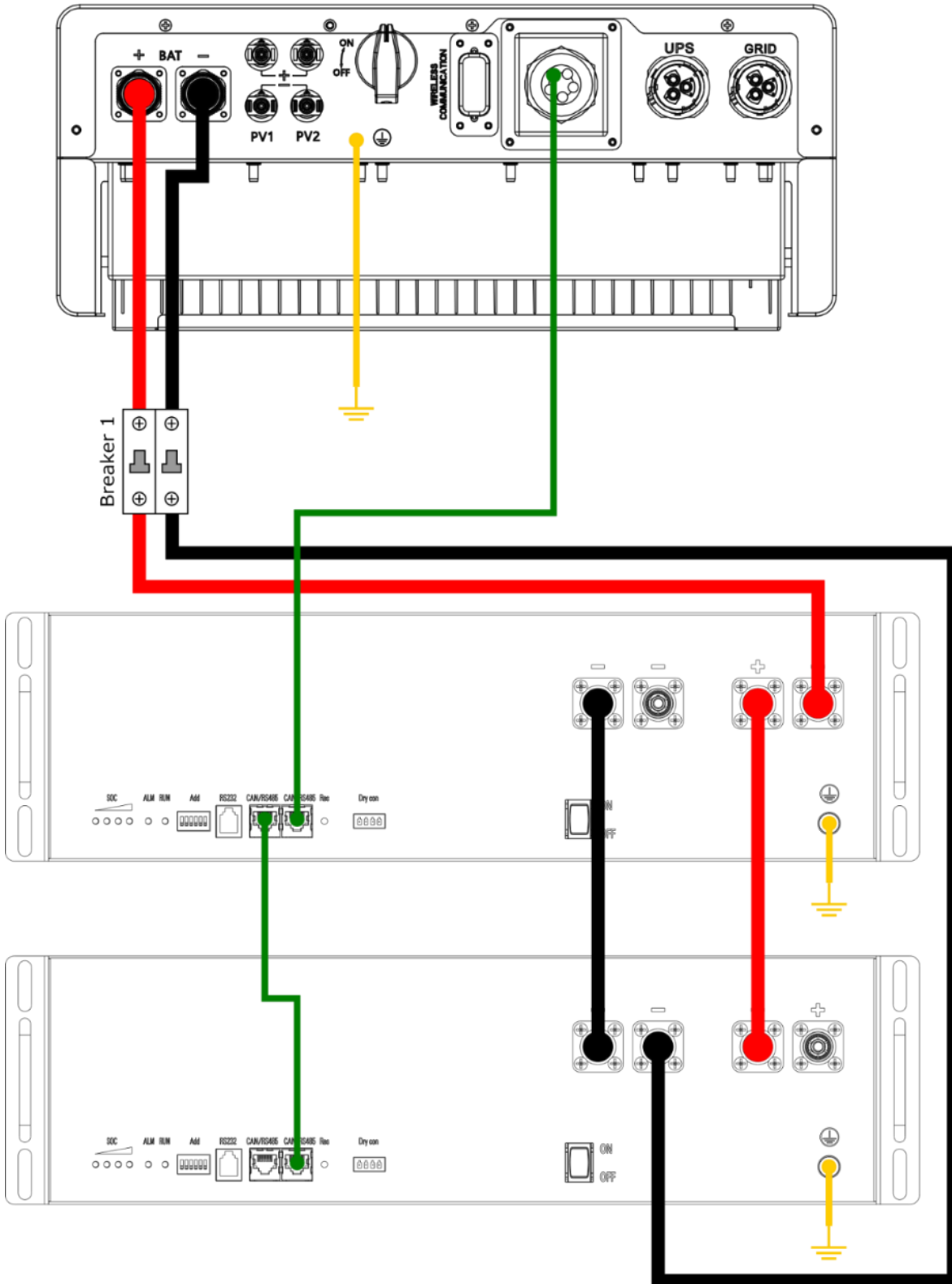

Example for 3 and more Batteries

Bus bar is required and a battery breaker per battery is recommended.

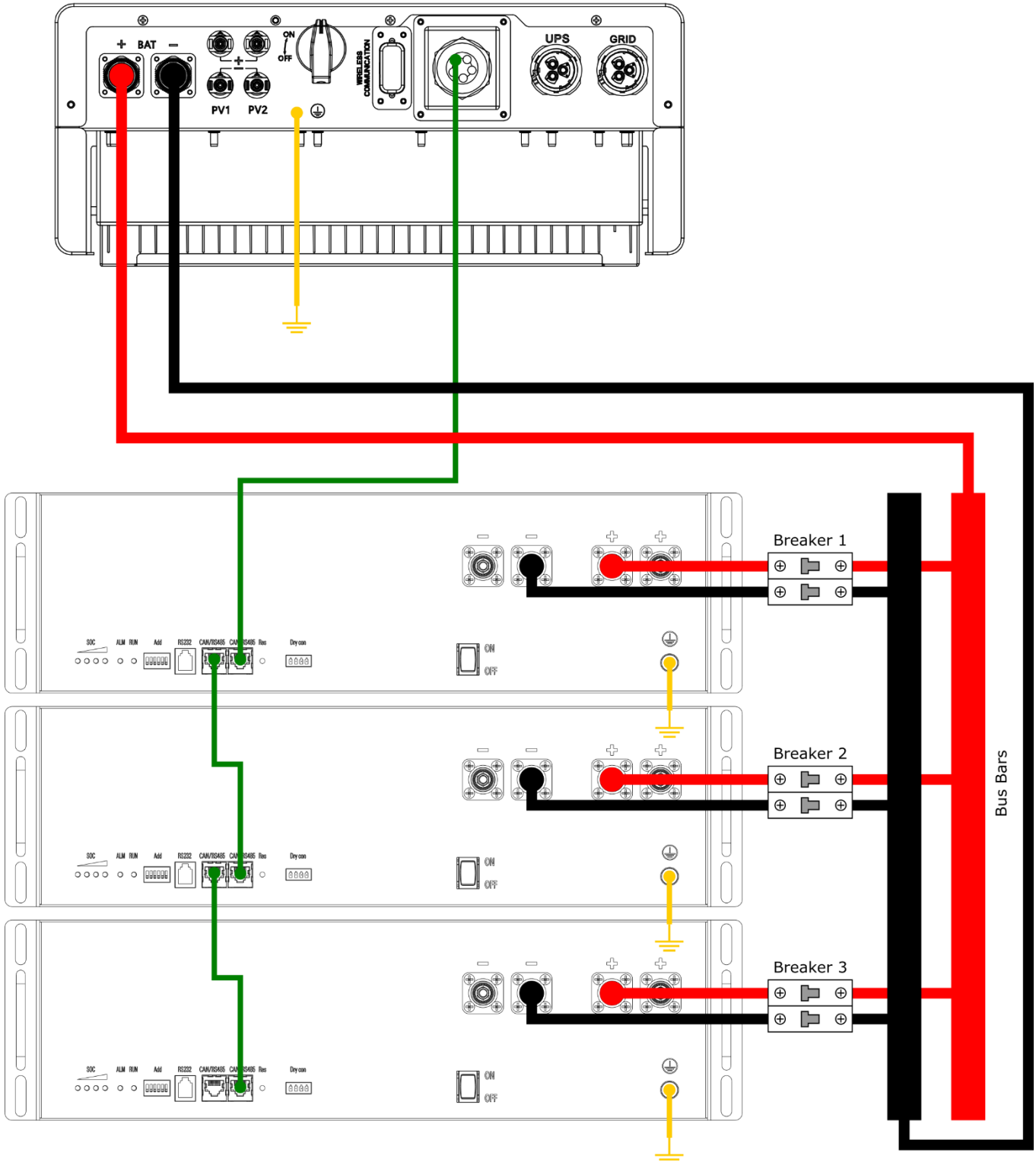



Megarevo

These examples apply to the following Luxpower inverters:

- REVO RKL1 series
- REVO RKLNA series

and show L051100-A1 Power Lite batteries. See [Battery Communication](#) for details regarding -A Power Lite batteries.

Inverter Firmware Version

The minimum firmware requirement is:

- For inverter model: R6KL1
Firmware: V1.01.39

CAN Communication Pinout

Luxpower inverters have the following relevant CAN pinout:

Pin	1	2	3	4	5	6	7	8
Function				CAN-H	CAN-L			

See section [Battery Communication](#) for the corresponding pins on the battery.

Inverter Settings

Set the battery type to “CUSTOMER-LITHIUM” or “CUSTOM-LI” as the “BAT TYPE”. In the case of “CUSTOM-LI”, the parameters are:

- CHARG-VOLT: 57.6V
- BAT END VOLT: 44V
- BAT OVP: 58V

Battery Quantities

The following quantities of batteries are recommended (see section [General Battery Quantities](#) for details), while of course more batteries can be used.



Inverter Model	AC Phases	AC Power Cont.	Max. Charge / Discharge Current Cont.	Power Lite Recommended Battery Qty.
R3KL1	1	3,000 W	95 / 62.5 A	2
R3K6L1	1	3,600 W	95 / 76.6 A	2
R4KL1	1	4,000 W	95 / 83.3 A	2
R4K6L1	1	4,600 W	95 / 95.8 A	2
R5KL1	1	5,000 W	95 / 110 A	2
R6KL1	1	6,000 W	95 / 110 A	2
R5KLNA	2	5,000 W	120 / 120 A	3
R6KLNA	2	6,000 W	135 / 135 A	3
R8KLNA	2	8,000 W	190 / 190 A	4
R10KLNA	2	10,000 W	210 / 210 A	4

Example for up to 2 Batteries

No bus bar required, and a single battery breaker is sufficient.

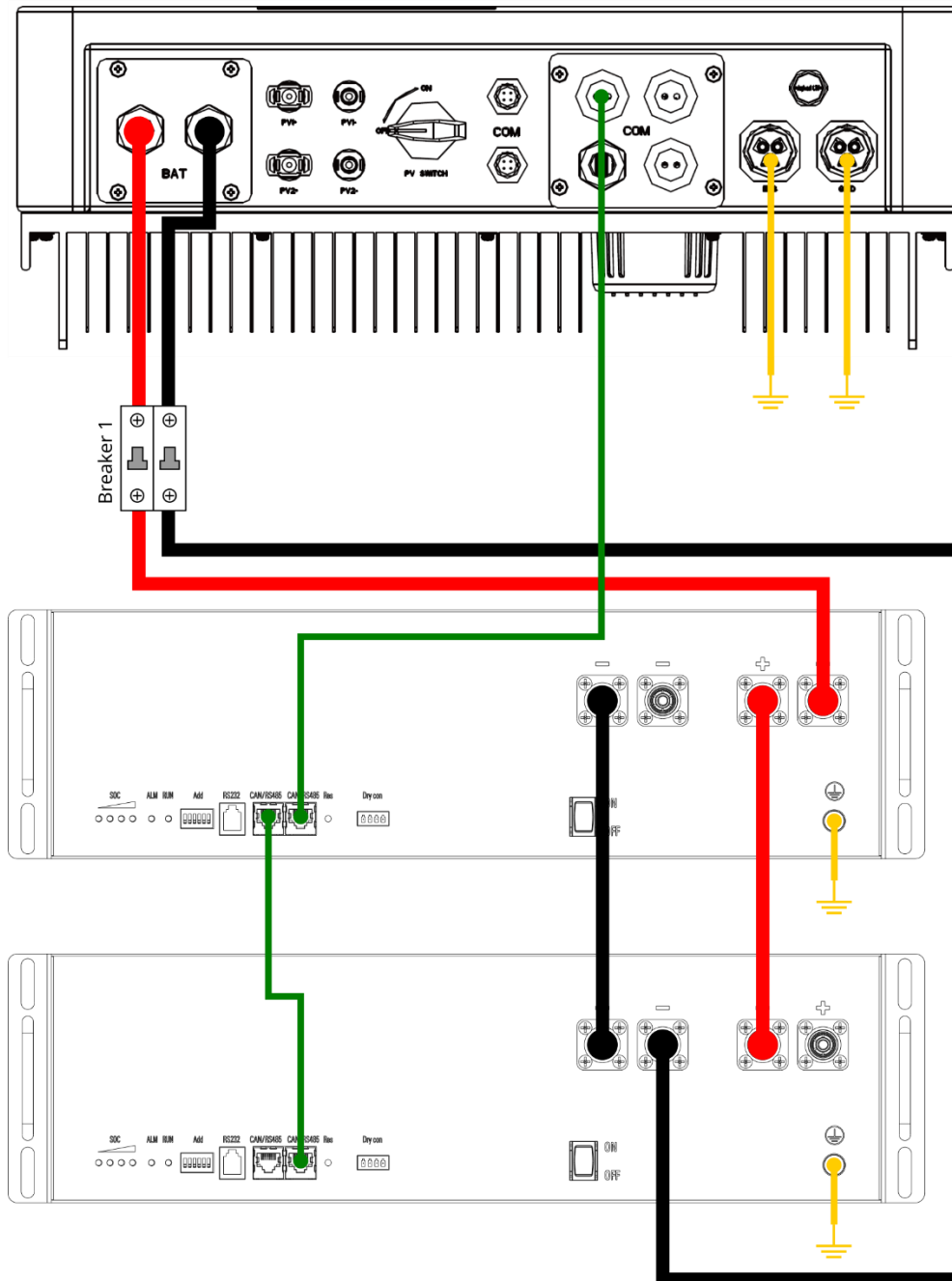

Example for 3 and more Batteries

Bus bar is required and a battery breaker per battery is recommended.

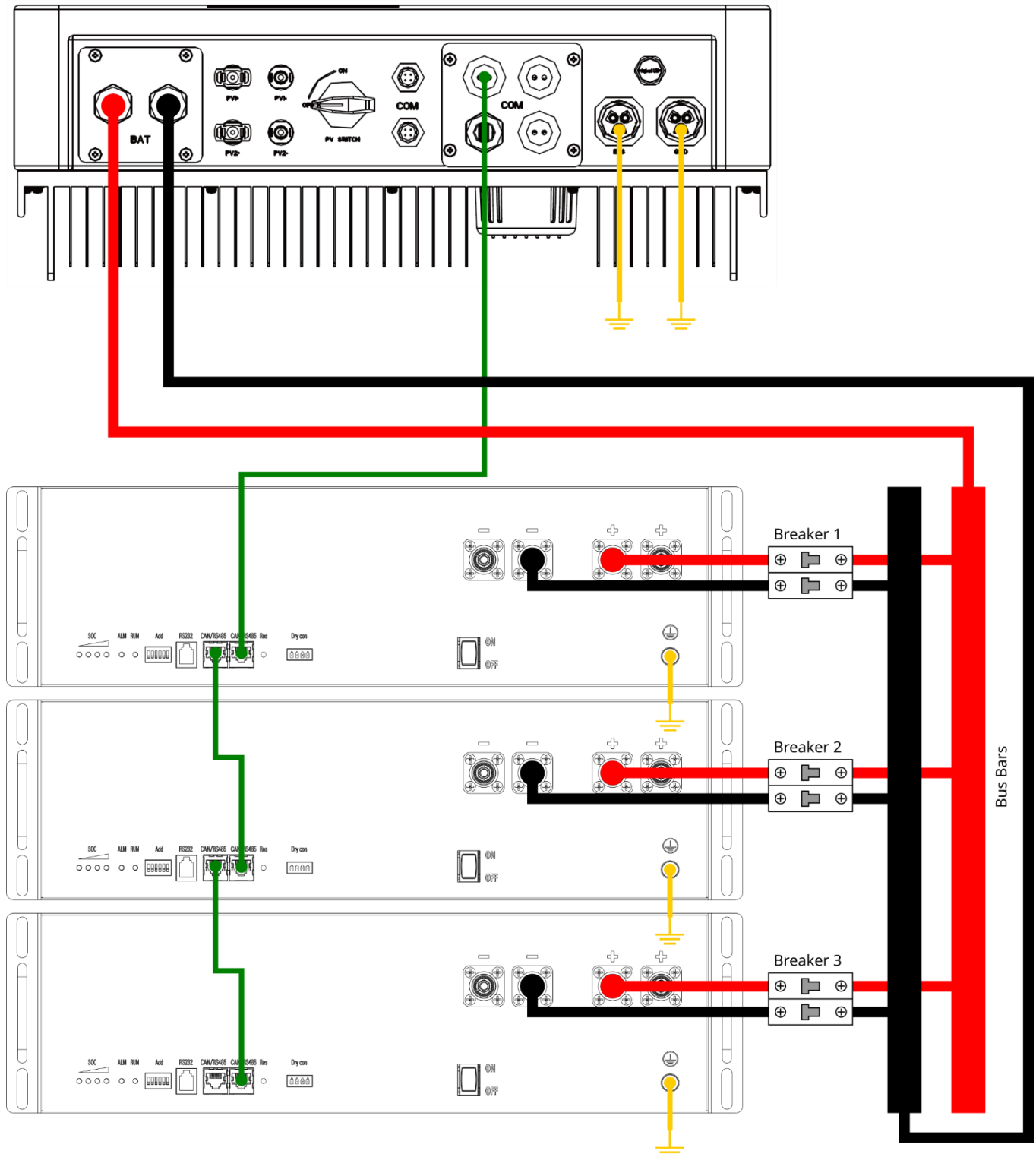



Phocos (Open-Loop)

These examples apply to the following Phocos inverters:

- PSW-H-5KW-230/48V
- PSW-H-5KW-120/48V
- PSW-H-6.5KW-120/48V
- PSW-H-8KW-230/48V

and show L051100-A Power Lite batteries. See [Battery Communication](#) for details regarding -A1, -B and -D Power Lite batteries.

Inverter Firmware Version

There is no minimum firmware requirement.

Communication

No communication is supported nor needed for Phocos inverters.

Inverter Settings

The following settings are recommended for the inverter, sorted by inverter settings menu entries:

02 charge current: XXX A → where the formula is: (no. of batteries x 50 A) / no. of inverters. So, 50 A for a single inverter and battery, 100 A or lower for a single inverter and 2 batteries, etc.

05 battery type: USE

12 set-point to grid: 49 V

13 set-point to off-grid: 53 to 55 V

26 bulk CV charge voltage: 55.2 V

27 floating voltage: 54.8 V

29 low battery cut-off: 48.0 V

30 battery equalization: disabled

32 bulk CV duration: 150 minutes (this settings menu may not be available)

Battery Quantities

The following quantities of batteries are recommended (see section [General Battery Quantities](#) for details), while of course more batteries can be used.

Inverter Model	AC Phases	AC Power Cont.	Power Lite Recommended Battery Qty.
PSW-H-5KW-230/48V	1	5,000 W	3
PSW-H-5KW-120/48V	1	5,000 W	3
PSW-H-6.5KW-120/48V	1	6,500 W	3
PSW-H-8KW-230/48V	1	8,000 W	4

Example for up to 2 Batteries

No bus bar required, and a single battery breaker is sufficient.

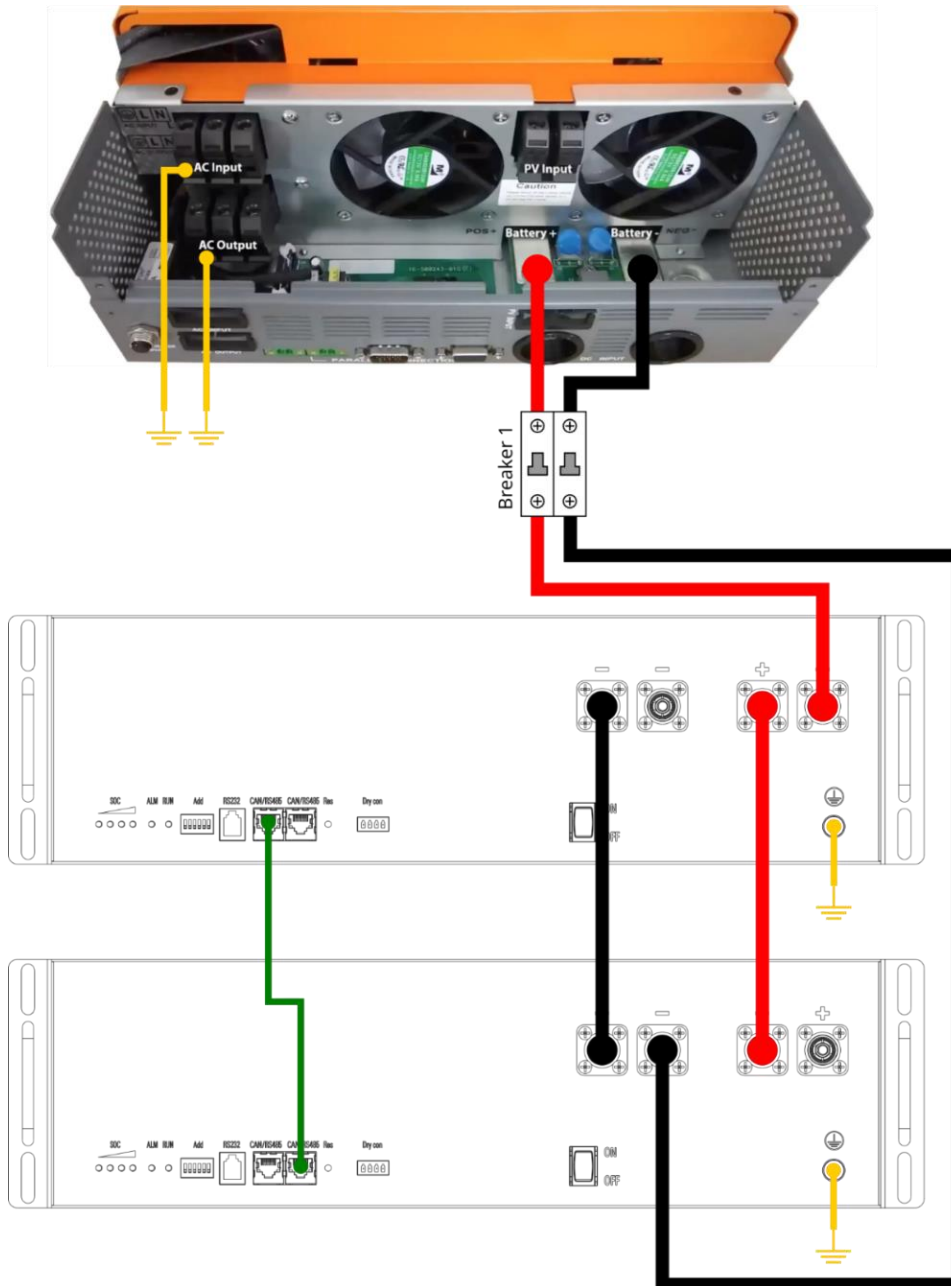

Example for 3 and more Batteries

Bus bar is required and a battery breaker per battery is recommended.

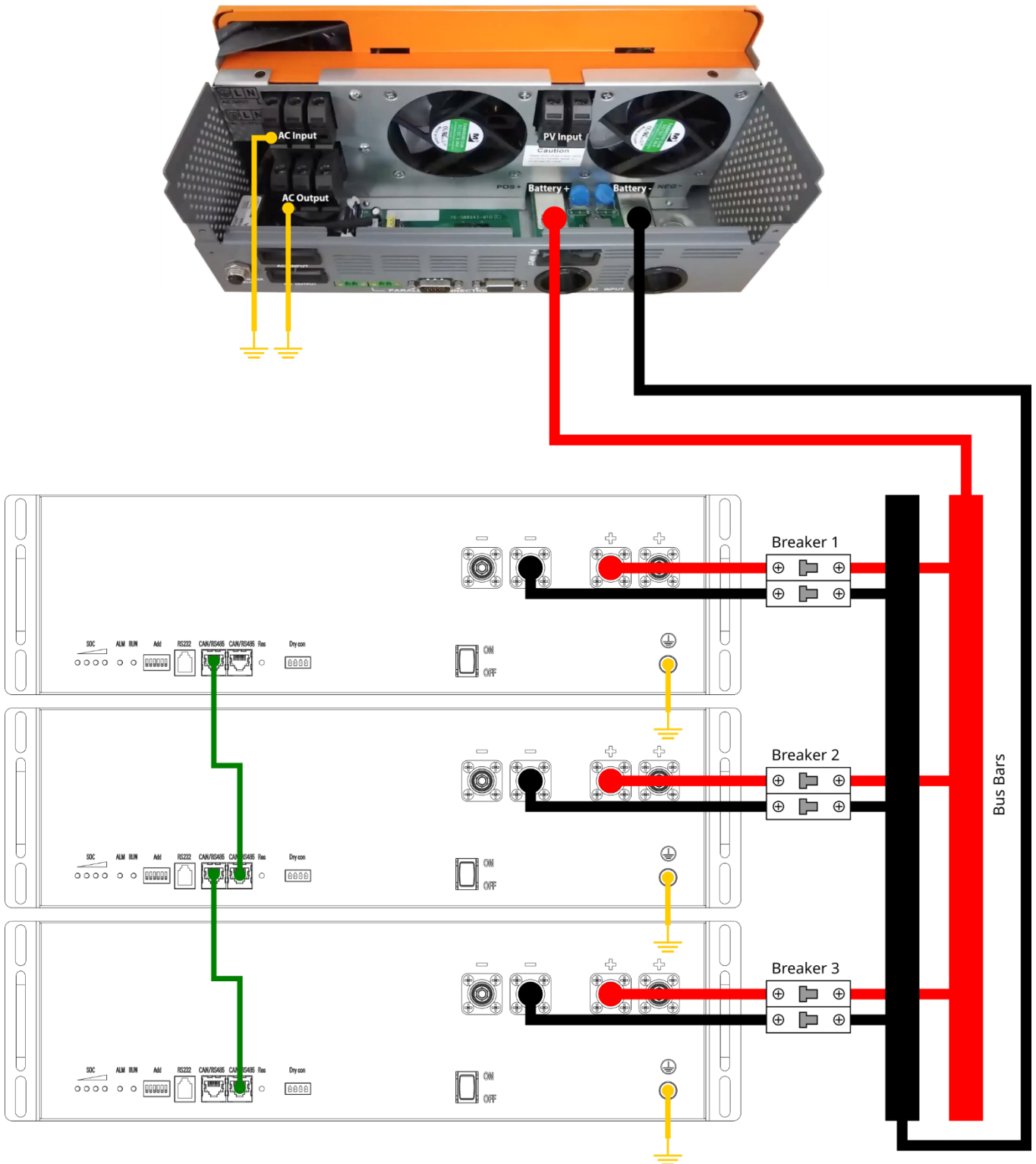

SAJ

These examples apply to the following SAJ inverters:

- H1-3K-S2
- H1-3.6K-S2
- H1-4K-S2
- H1-4.6K-S2
- H1-5K-S2
- H1-6K-S2

and show L051100-A Power Lite batteries. See [Battery Communication](#) for details regarding -A1, -B and -D Power Lite batteries.

Inverter Firmware Version

The minimum firmware requirement is:

- For inverter model: H1-3K-S2
Firmware: V1.325

CAN Communication Pinout

SAJ inverters have the following relevant CAN pinout:

Pin	1	2	3	4	5	6	7	8
Function				CAN-H	CAN-L			

See section [Battery Communication](#) for the corresponding pins on the battery.

Battery Quantities

The following quantities of batteries are recommended (see section [General Battery Quantities](#) for details), while of course more batteries can be used.

Inverter Model	AC Phases	AC Power Cont.	Max. Charge / Discharge Current Cont.	Power Lite Recommended Battery Qty.
H1-3K-S2	1	3,000 W	60 A	2
H1-3.6K-S2	1	3,680 W	60 A	2
H1-4K-S2	1	4,000 W	60 A	2
H1-4.6K-S2	1	4,600 W	100 A	2
H1-5K-S2	1	5,000 W	100 A	2
H1-6K-S2	1	6,000 W	100 A	2

Example for up to 2 Batteries

No bus bar required, and a single battery breaker is sufficient.

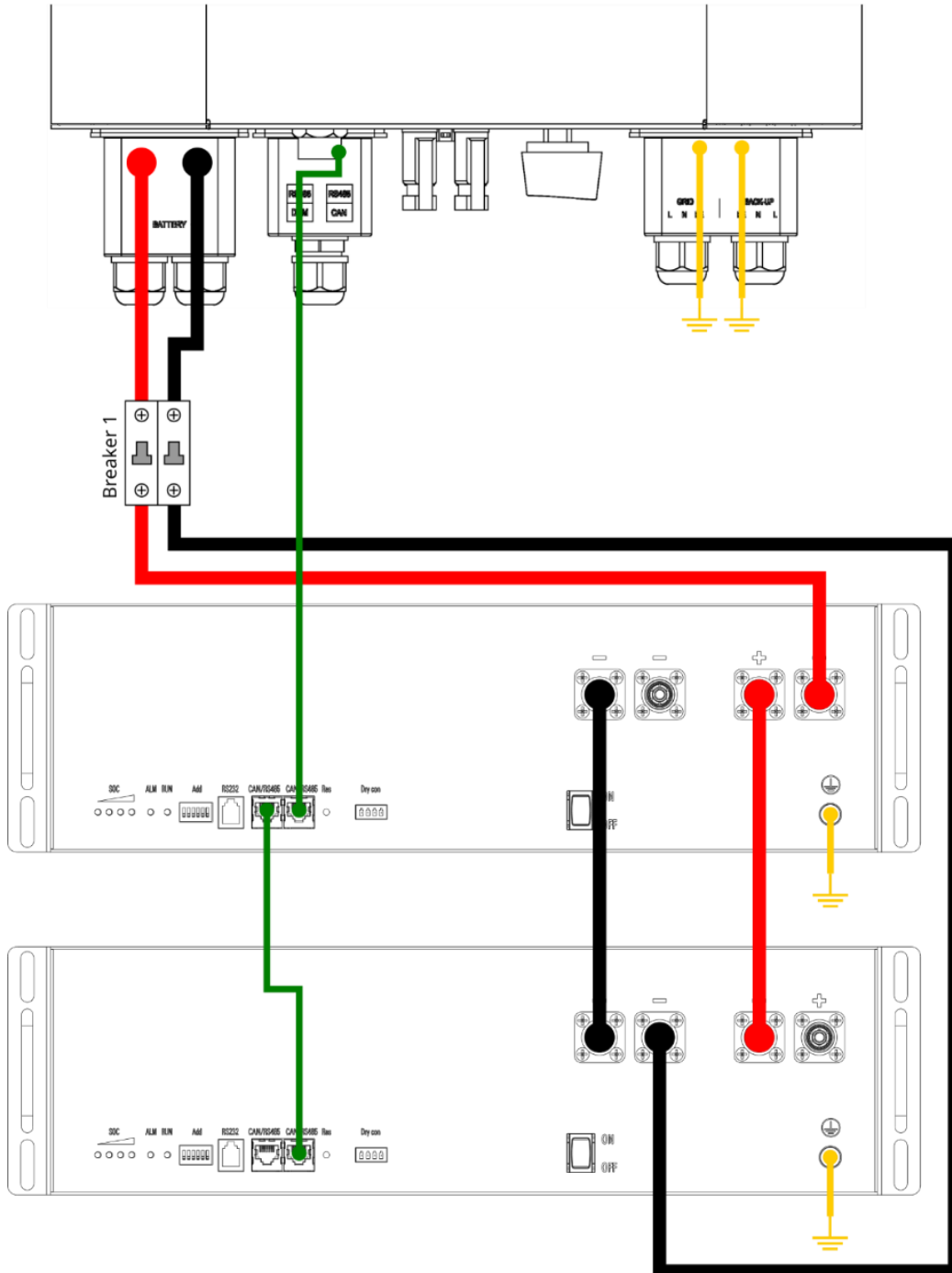

Example for 3 and more Batteries

Bus bar is required and a battery breaker per battery is recommended.

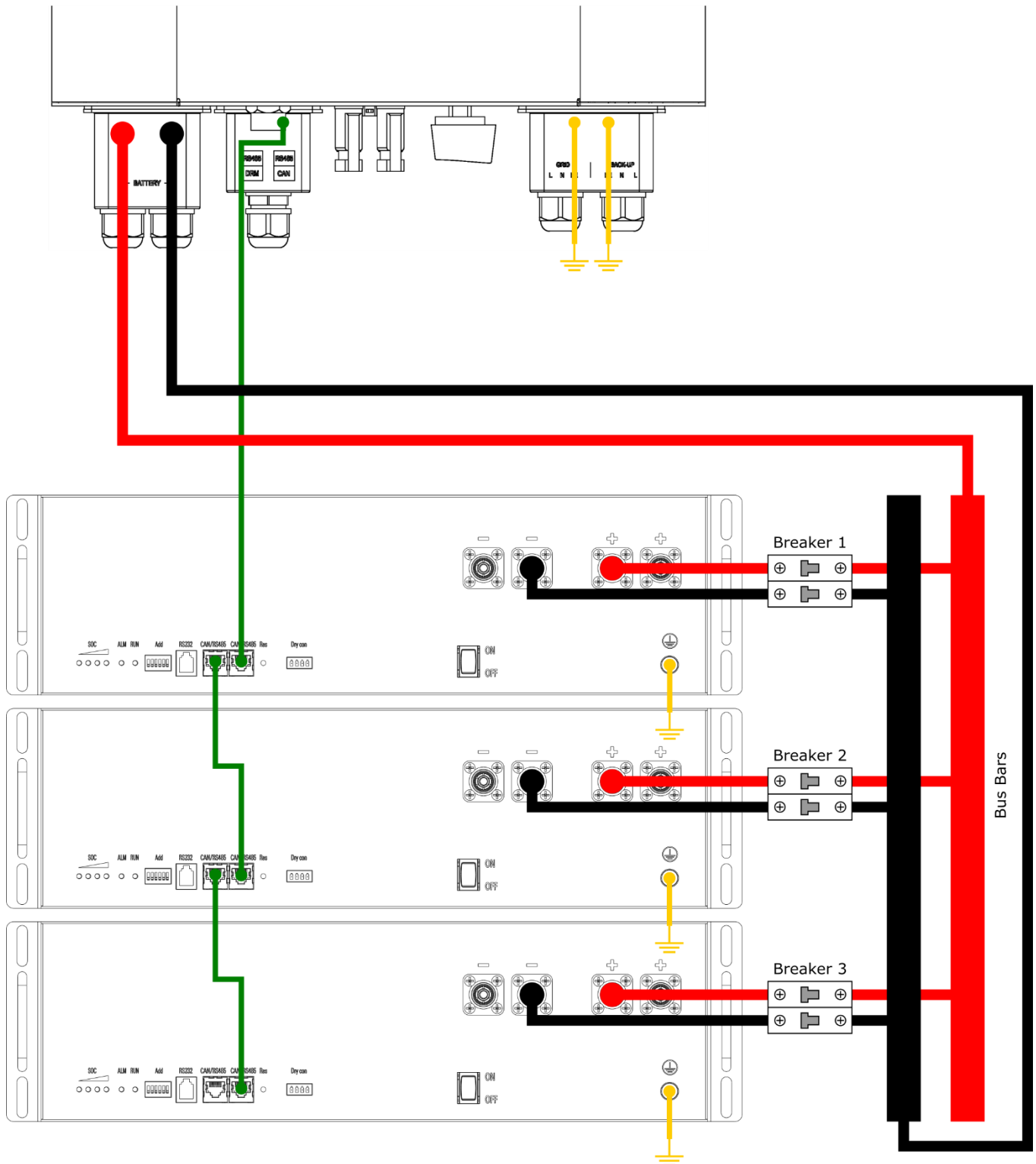

SMA

These examples apply to the following SMA inverters:

- Sunny Island SI 4.4-M
- Sunny Island SI 6.0-H
- Sunny Island SI 8.0-H

and show L051100-A1 Power Lite batteries. L051100-A batteries are not approved by SMA and thus not covered here.

Inverter Firmware Version

The minimum firmware requirement is:

- For inverter model: SI 6.0-H
Firmware: 3.21.4.R

Battery Firmware Version

SMA has tested and approved Power Lite -A1, -B and -D batteries with a special firmware. Find the corresponding firmware in the section [Battery Firmware Overview](#).

CAN Communication Pinout

SMA inverters have the following relevant CAN pinout:

Pin	1	2	3	4	5	6	7	8
Function		GND		CAN-H	CAN-L			

See section [Battery Communication](#) for the corresponding pins on the battery.

Note: It is normal for the battery alarm LED to blink red 15 minutes after turning on the battery if there is no communication with the inverter and for the BMS to disconnect the battery internally. This is intentional and a requirement by SMA.

Inverter Settings

Set the following battery parameters to enable communication with the battery:

- BatTyp (battery type): Li-Ion
- BatVtgLst (nominal battery voltage): 51.2 V
- BatCpyNom (nominal battery capacity): number of batteries in parallel x 100 Ah (ex. for 3 batteries: 300 Ah)

Battery Quantities

The following quantities of batteries are recommended (see section [General Battery Quantities](#) for details), while of course more batteries can be used.

Inverter Model	AC Phases	AC Power Cont.	Max. Discharge Current Cont.	Power Lite Recommended Battery Qty.
----------------	-----------	----------------	------------------------------	-------------------------------------



SI 4.4-M	1	3,300 W	75 A	2
SI 6.0-H	1	4,600 W	103 A	2
SI 8.0-H	1	6,000 W	130 A	3
SI 4.4-M x 3 pcs.	3	9,900 W	225 A	5
SI 6.0-H x 3 pcs.	3	13,800 W	309 A	7
SI 8.0-H x 3 pcs.	3	18,000 W	390 A	8

Example for up to 2 Batteries

No bus bar required, and a single battery breaker is sufficient.

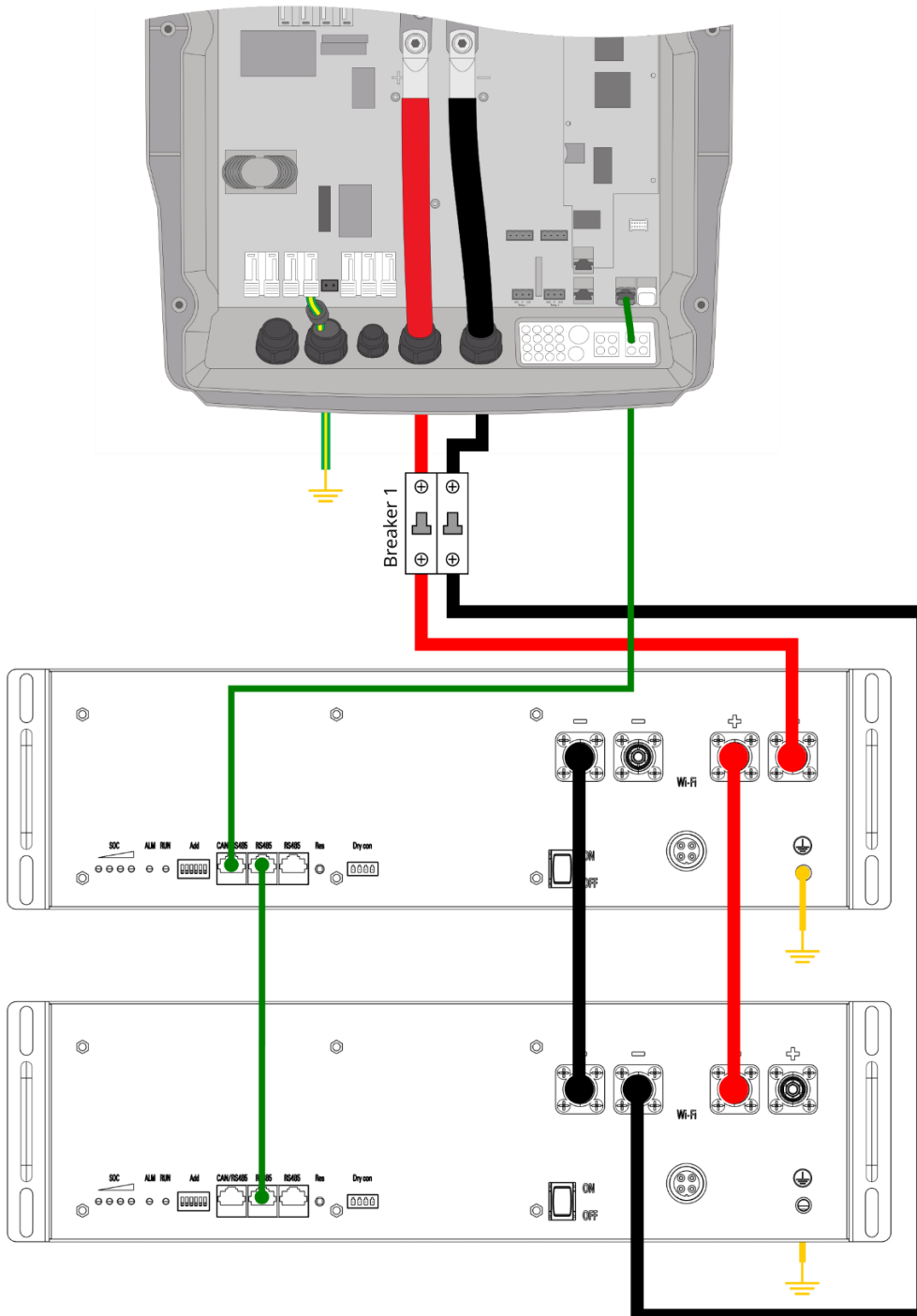

Example for 3 and more Batteries

Bus bar is required and a battery breaker per battery is recommended.

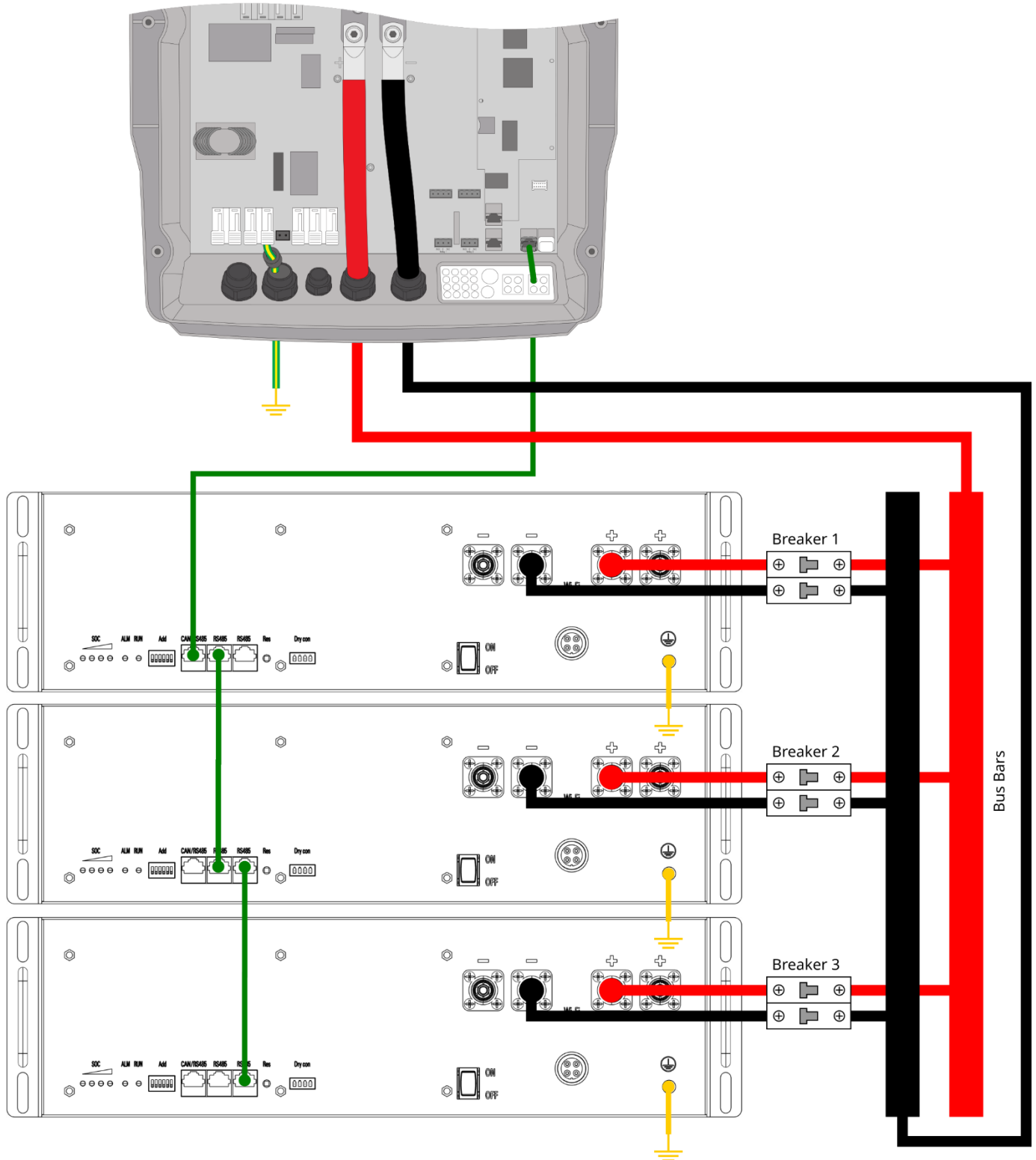

Sofar

These examples apply to the following Sofar inverters:

- ME 3000SP
- HYD series

and show L051100-A Power Lite batteries. See [Battery Communication](#) for details regarding -A1, -B and -D Power Lite batteries.

Inverter Firmware Version

The minimum firmware requirement is:

- For inverter model: HYD6000-EP
Firmware: V030321

CAN Communication Pinout

Sofar inverters have the following relevant CAN pinout:

Pin	1	2	3	4	5	6	7	8
Function	CAN-H	CAN-L						

See section [Battery Communication](#) for the corresponding pins on the battery.

Battery Quantities

The following quantities of batteries are recommended (see section [General Battery Quantities](#) for details), while of course more batteries can be used.

Inverter Model	AC Phases	AC Power Cont.	Max. Charge / Discharge Current Cont.	Power Lite Recommended Battery Qty.
HYD 3000-EP	1	3,000 W	100 A / 100 A	2
HYD 3680-EP	1	3,680 W	100 A / 100 A	2
HYD 4000-EP	1	4,000 W	100 A / 100 A	2
HYD 4600-EP	1	4,600 W	100 A / 100 A	2
HYD 5000-EP	1	5,000 W	100 A / 100 A	2
ME 3000SP	1	3,000 W	65 A / 70 A	2

Example for up to 2 Batteries

No bus bar required, and a single battery breaker is sufficient.

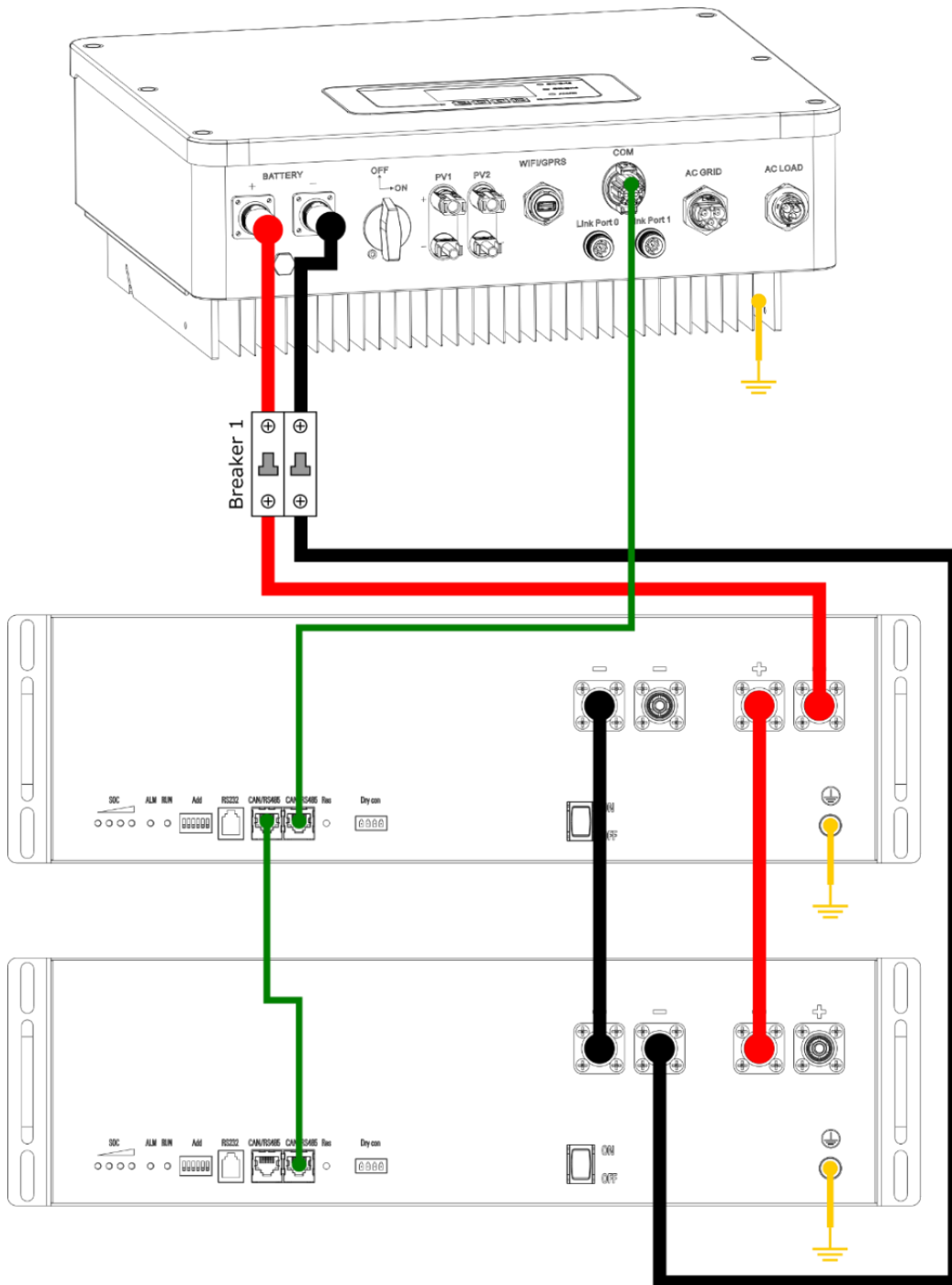

Example for 3 and more Batteries

Bus bar is required and a battery breaker per battery is recommended.

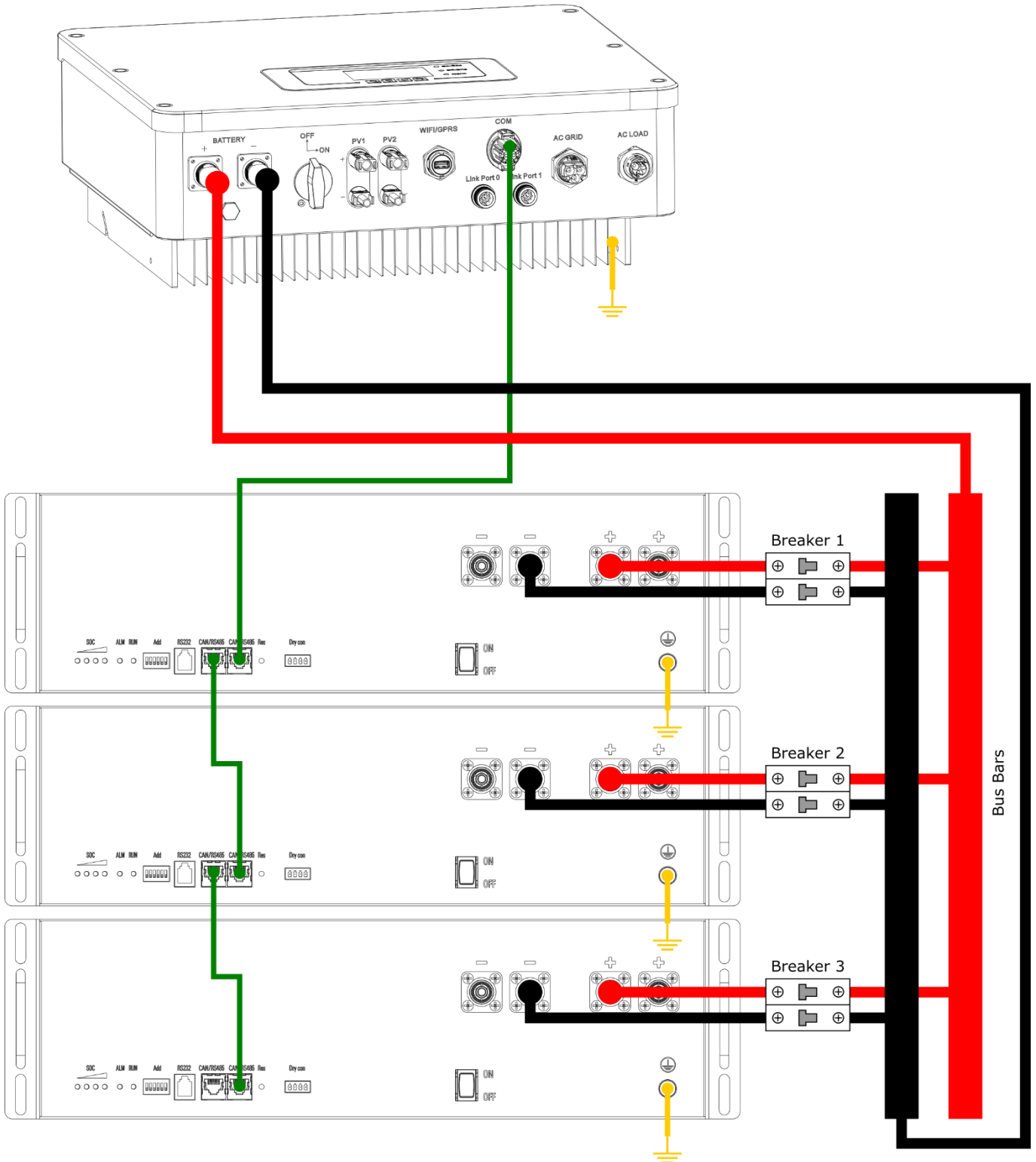

Sol-Ark

These examples apply to the following Sol-Ark inverters:

- 5K-120V-1P
- 5K-2P-N
- 8K-230V-1P
- 12K-P-N
- 15K-P-N

and show L051100-A Power Lite batteries. See [Battery Communication](#) for details regarding -A1, -B and -D Power Lite batteries.

CAN Communication Pinout

Sol-Ark inverters have the following relevant CAN pinout:

Pin	1	2	3	4	5	6	7	8
Function		GND		CAN-H	CAN-L			

See section [Battery Communication](#) for the corresponding pins on the battery.

Cable Kit

Inverter Model	Cable Kit	Communication Cable	Power Cables (x2)
All compatible Sol-Ark inverters	CA04	1.5m, RJ45→RJ45	1.5m, Hot-plug→Ring terminal M10

Inverter Settings

Set the battery type to “Lithium” and ensure the battery capacity corresponds to the number of Power Lite batteries used x 100 Ah. Also check the “Max A Charge” and “Max A Discharge” are set to the number of Power Lite batteries used x 50 A. Depending on the inverter and number of batteries used, sometimes only a lower number may be entered for the charge / discharge current, this is a limitation of the inverter and not an issue. Finally, also check that the “Lithium Mode” is set to “00”. Ensure “Activate Battery” is checked. This example shows a configuration for 3 batteries.

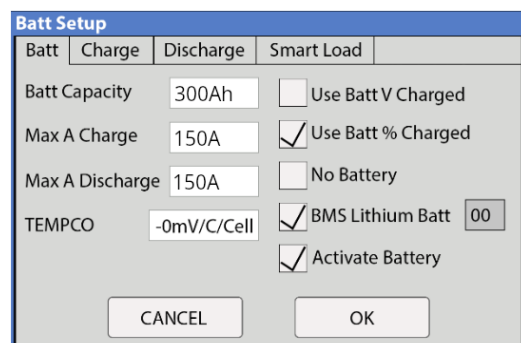

Batt	Charge	Discharge	Smart Load
Batt Capacity	300Ah	<input type="checkbox"/> Use Batt V Charged	
Max A Charge	150A	<input checked="" type="checkbox"/> Use Batt % Charged	
Max A Discharge	150A	<input type="checkbox"/> No Battery	
TEMPCO	-0mV/C/Cell	<input checked="" type="checkbox"/> BMS Lithium Batt	00
		<input checked="" type="checkbox"/> Activate Battery	
CANCEL		OK	

**Battery Quantities**

Inverter Model	AC Phases	AC Power Cont.	Max. Charge / Discharge Current Cont.	Power Lite Recommended Battery Qty.
5K-1P (5K-120V)	1	4,800 W	120 A	3
8K-1P (8K-230V-1P)	1	8,000 W	120 A	3
5K-2P-N	2	5,000 W	120 A	3
8K-2P-N	2	8,000 W	185 A	4
12K-2P-N	2	9,000 W	185 A	4
15K-2P-N	2	12,000 W	275 A	6

Example for up to 2 Batteries

No bus bar required, and a single battery breaker is sufficient.

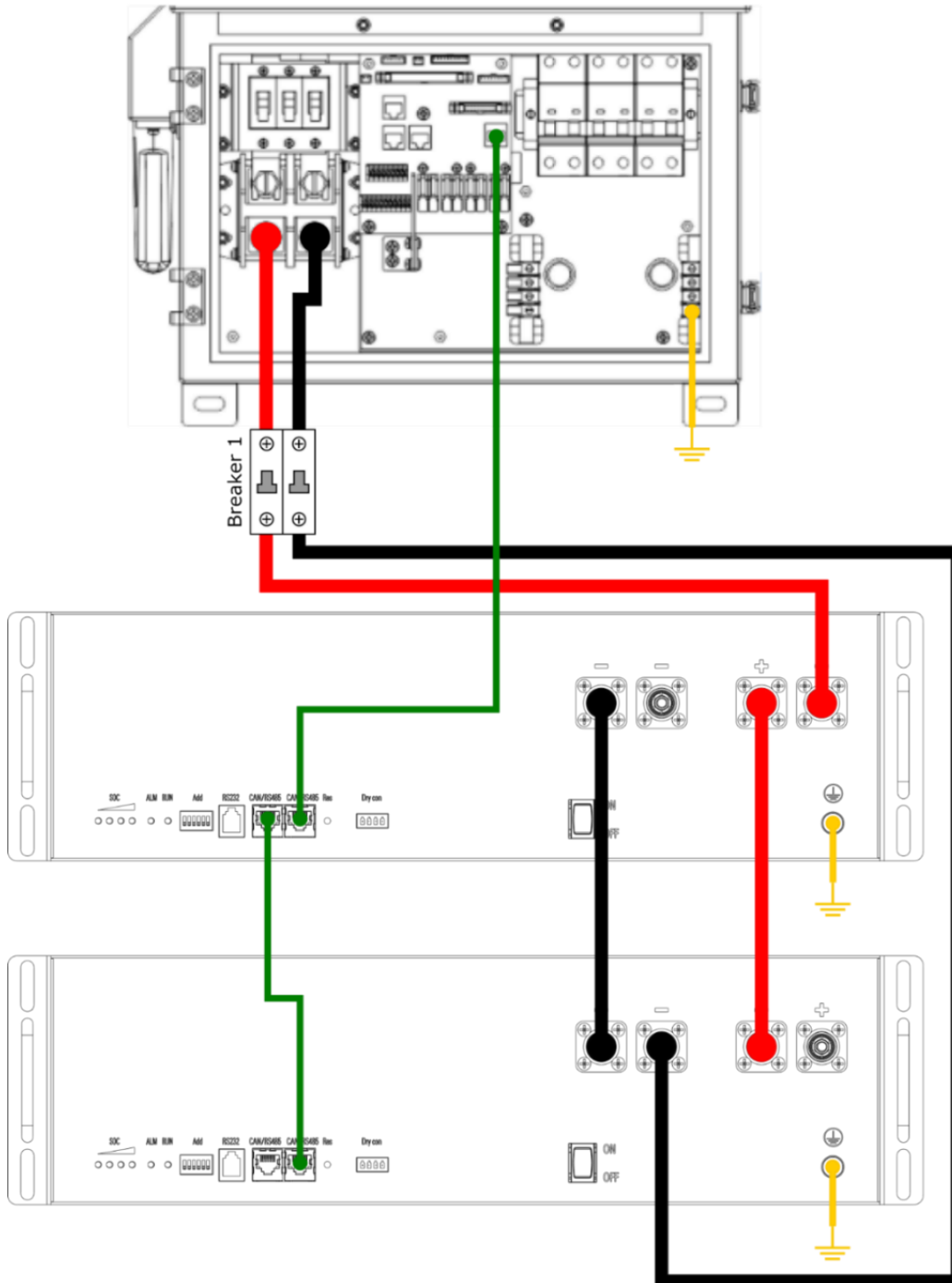

Example for 3 and more Batteries

Bus bar is required and a battery breaker per battery is recommended.

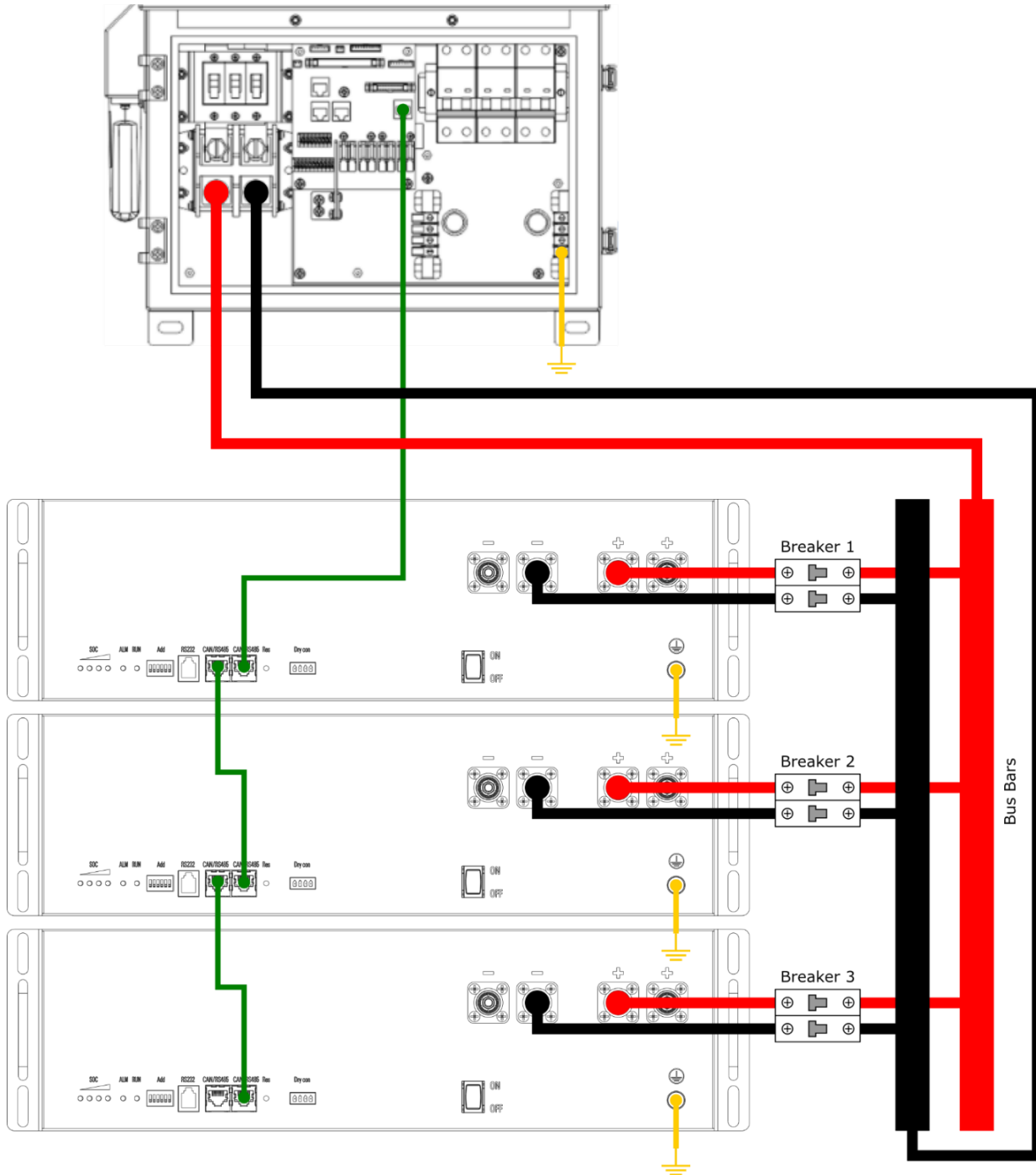



Solis

These examples apply to the following Solis inverters:

- RAI-3K series
- RHI-3-6K (5G) series
- S5-EH1P(3-6)K-L series

and show L051100-A Power Lite batteries. See [Battery Communication](#) for details regarding -A1, -B and -D Power Lite batteries.

Inverter Firmware Version

The minimum firmware requirement is:

- For inverter model: RAI-3K-48ES-5G
Firmware: B103A200, AcCou_3k_VA2_MF9.bin
HMI: V11
- For inverter model: RHI-5K-48ES-5G
Firmware: 3300A2, CN_5G_5k_VA2_MF3.bin
HMI: V37
- For inverter model: RHI-6K-48ES-5G
Firmware: 33002A, CN_5G_6k_VA2_MF6.bin
HMI: V37
- For inverter model: S5-EH1P(3-6)K-L series
HMI: V37

Battery Firmware Version

Find the corresponding firmware in the section [Battery Firmware Overview](#). A change has been made to the battery firmware to accommodate Solis inverters in December 2022, so if the battery firmware is older than this date, please update. The date is encoded in the firmware version string and can be read using the UIWARE software available at the link in the [Battery Firmware Overview](#) table. To interpret the date of the installed firmware see this example firmware version number:

LM-M01S-YZ109-21.Z0.18-221206, the highlighted portion in this example corresponds with the date of 2022-12-06 or December 6th 2022.

CAN Communication Pinout

Solis inverters have the following relevant CAN pinout:

Pin	1	2	3	4	5	6	7	8
Function		GND		CAN-H	CAN-L			

See section [Battery Communication](#) for the corresponding pins on the battery.

Cable Kit

Inverter Model	Cable Kit	Communication Cable	Power Cables
RAI-3K series			
RHI-3-6K (5G) series	CA03	1.5m, RJ45→RJ45	1.5m, Hot-plug→Ring terminal M8 (replace ring terminal with Amphenol connectors included with inverter)
S5-EH1P(3-6)K-L series	CA03	1.5m, RJ45→RJ45	1.5m, Hot-plug→Ring terminal M8 (replace ring terminal with Amphenol connectors included with inverter)

Inverter Settings

Under “Battery Select”, choose “UZ” as the “Battery Module”. If this setting is not available, choose “CATL”:

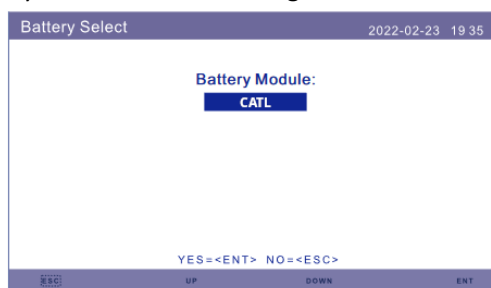
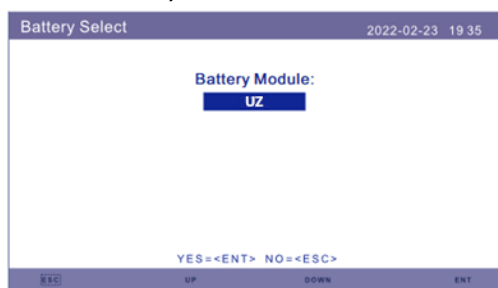

Battery Quantities

The following quantities of batteries are recommended (see section [General Battery Quantities](#) for details), while of course more batteries can be used.

Inverter Model	AC Phases	Max. Charge / Discharge Power	Max. Charge / Discharge Current Cont.	Power Lite Recommended Battery Qty.
RAI-3K-48ES-5G	1	3,000 W	62.5 A	2
RHI-3K-48ES(-5G) S5-EH1P3K-L	1	3,000 W	62.5 A	2
RHI-3.6K-48ES-5G S5-EH1P3.6K-L	1	3,000 W	62.5 A	2
RHI-4.6K-48ES-5G S5-EH1P4.6K-L	1	5,000 W	100 A	2
RHI-5K-48ES-5G S5-EH1P5K-L	1	5,000 W	100 A	2
RHI-6K-48ES-5G S5-EH1P6K-L	1	5,000 W	100 A	2

Example for up to 2 Batteries

No bus bar required, and a single battery breaker is sufficient.

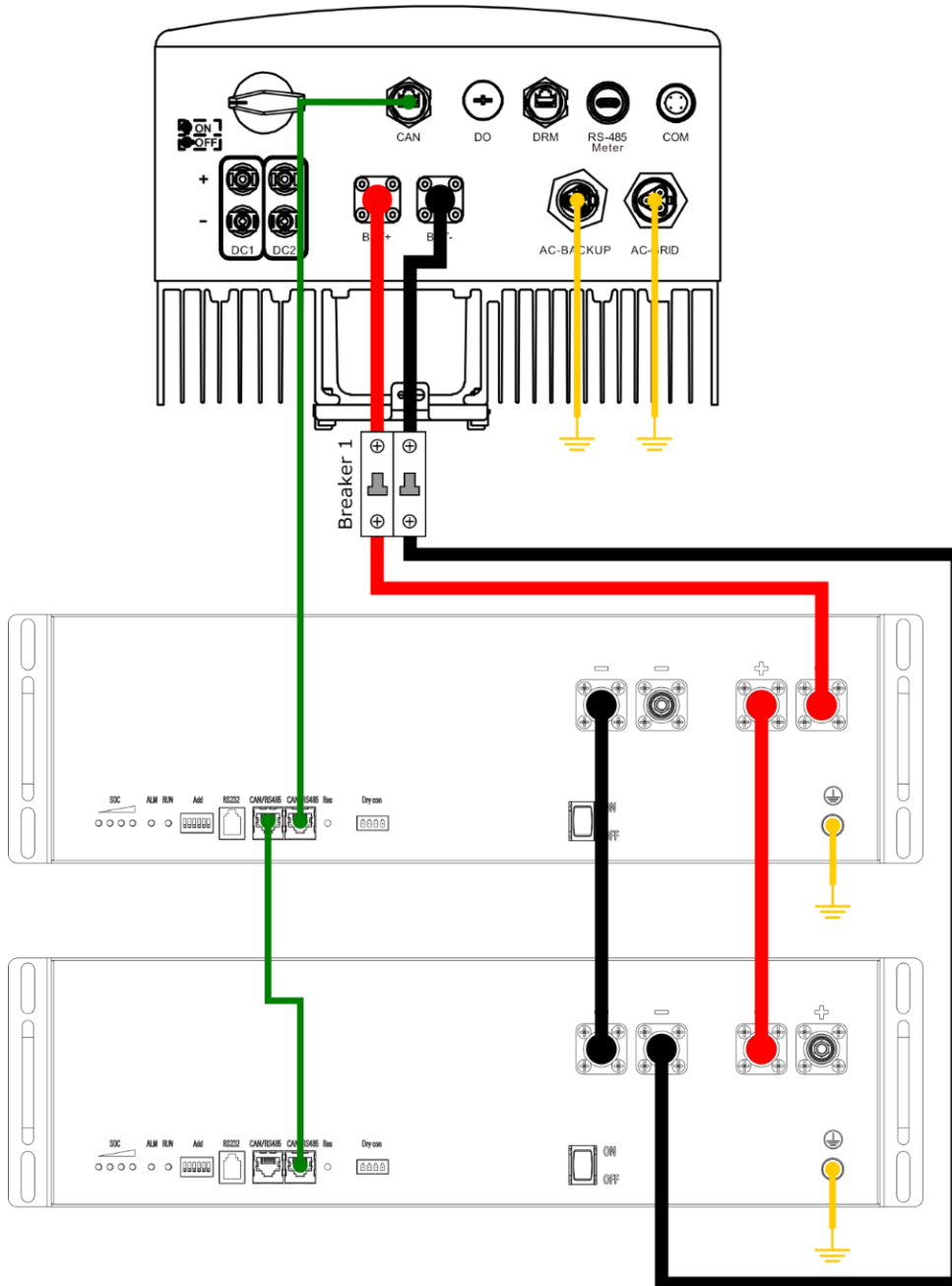

Example for 3 and more Batteries

Bus bars are normally required and a battery breaker per battery is recommended. However, because the listed Solis inverters up to 6 kW can source and sink a maximum of 100 A from and to the battery, a bus bar is not strictly needed for more than 2 batteries, if a single inverter is used. If not using a bus bar, refer to the previous example for up to 2 batteries above.

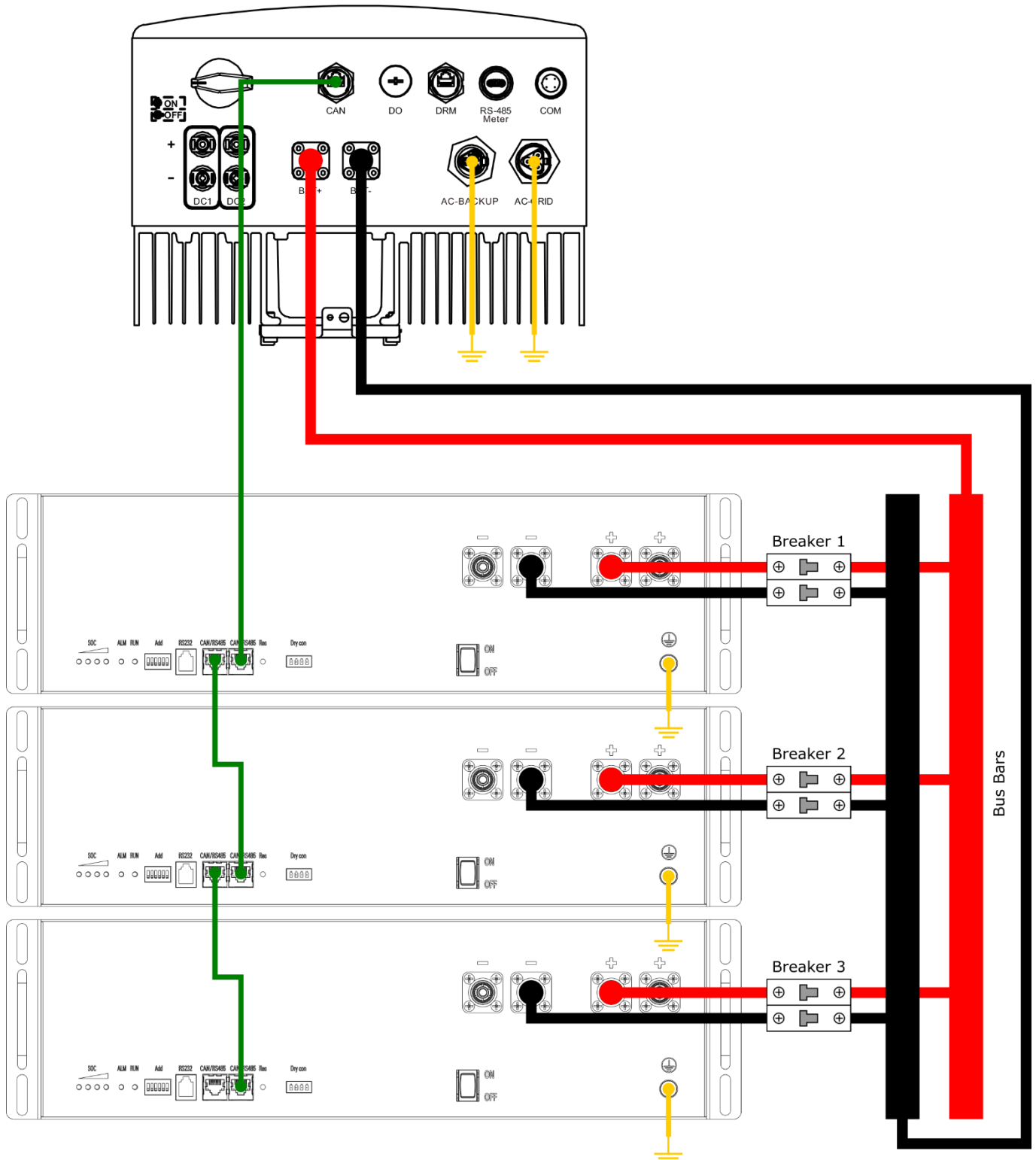



Solplanet

These examples apply to the following Solis inverters:

- ASW H-S2 series

and show L051100-A1 Power Lite batteries. See [Battery Communication](#) for details regarding -A1, -B and -D Power Lite batteries. -A batteries have not been tested with this inverter.

Inverter Firmware Version

The minimum inverter firmware requirement is V610-02003-96.

Power Lite L051100 Battery Firmware Version

Find the corresponding firmware in the section [Battery Firmware Overview](#). The minimum tested firmware version is LM-M01S-YZ109-221107.

CAN Communication Pinout

Solis inverters have the following relevant CAN pinout:

Pin	1	2	3	4	5	6	7	8
Function		GND		CAN-H	CAN-L			

See section [Battery Communication](#) for the corresponding pins on the battery.

Cable Kit

Inverter Model	Cable Kit	Communication Cable	Power Cables
ASW H-S2 series	CA03	1.5m, RJ45→RJ45	1.5m, Hot-plug→Ring terminal M8

Inverter Settings

Under “Battery settings”, choose “UZ Energy → BL051100-A1” as the battery:



← Battery settings

Pylontech	Power Lite
DYNESS	<input checked="" type="checkbox"/> BL051100-A1
	BL051200-A1
BYD	L048027-AS
LG	L048050-AS
Solplanet	
UZ Energy	
TAICO	
KNOX	
Poweroad	

Confirm

Battery Quantities

The following quantities of batteries are recommended (see section [General Battery Quantities](#) for details), while of course more batteries can be used.

Inverter Model	AC Phases	Max. Charge / Discharge Power	Max. Charge / Discharge Current Cont.	Power Lite Recommended Battery Qty.
ASW3000H-S2 to ASW6000H-S2	1	3,000 W ~ 6,000 W	100 A	2

Example for up to 2 Batteries

No bus bar required, and a single battery breaker is sufficient.

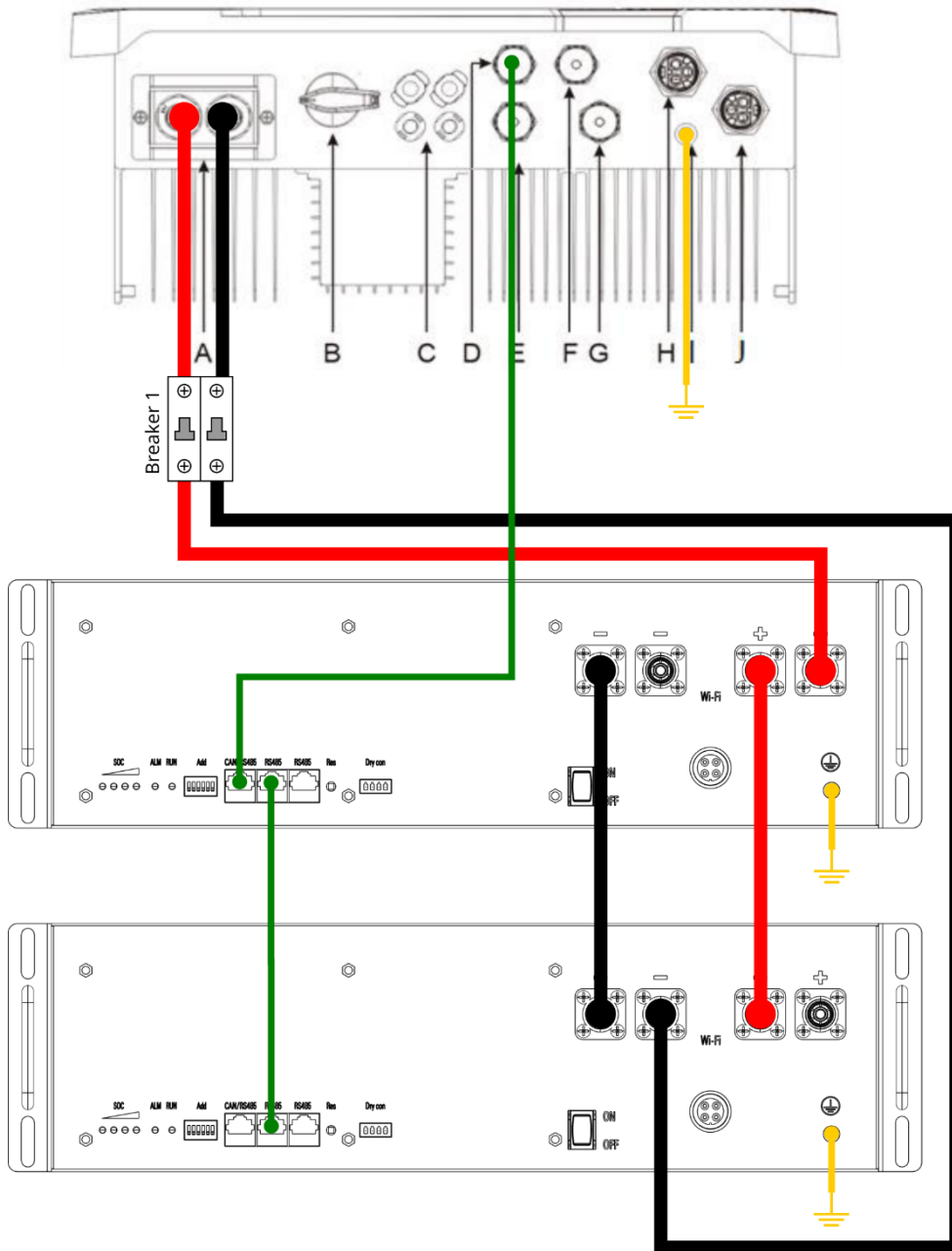

Example for 3 and more Batteries

Bus bars are normally required and a battery breaker per battery is recommended. However, because the listed Solis inverters up to 6 kW can source and sink a maximum of 100 A from and to the battery, a bus bar is not strictly needed for more than 2 batteries, if a single inverter is used. If not using a bus bar, refer to the previous example for up to 2 batteries above.

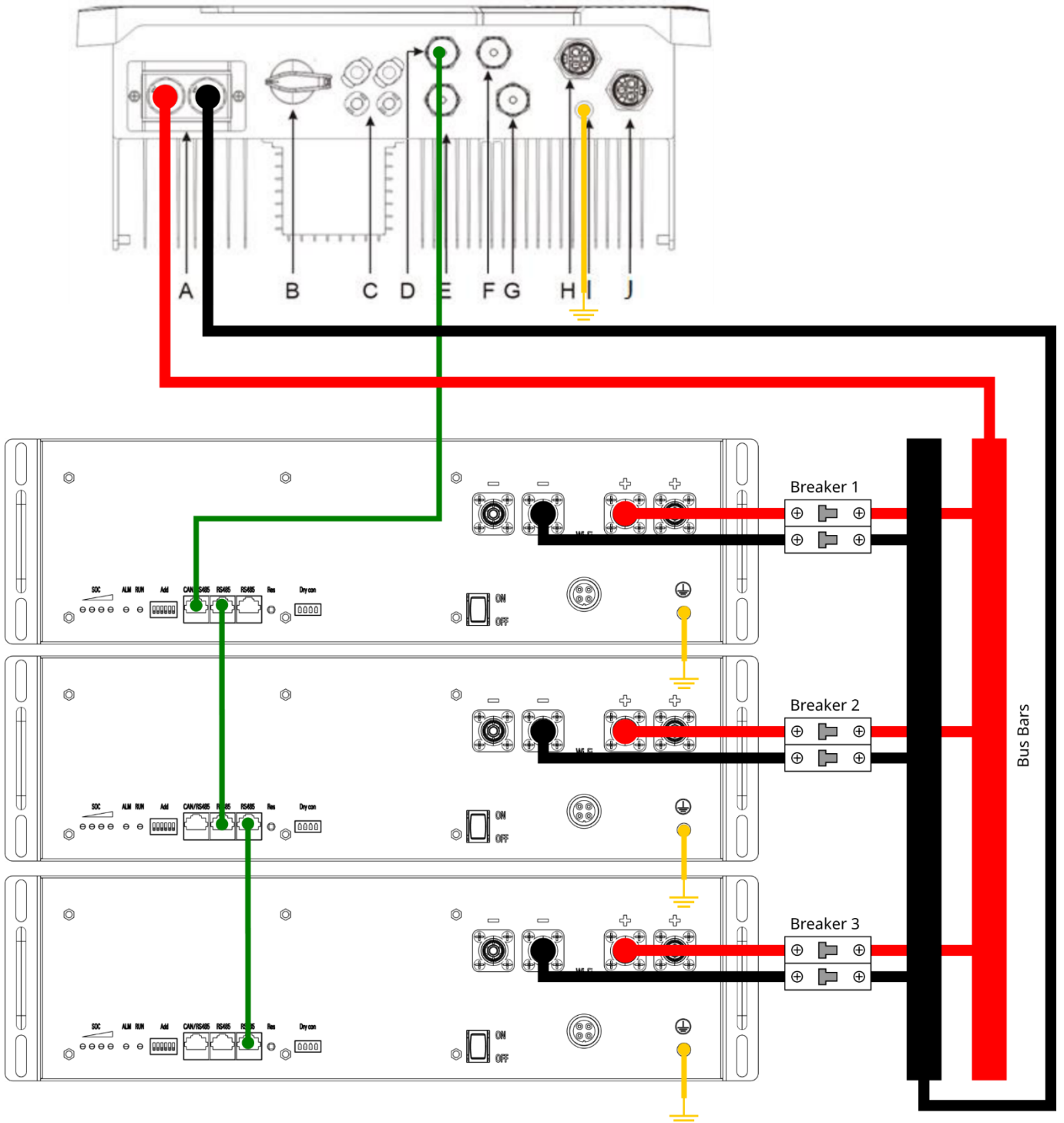



Steca (Open-Loop)

These examples apply to the following Steca inverters:

- PLI 5000-48

and show L051100-A Power Lite batteries. See [Battery Communication](#) for details regarding -A1, -B and -D Power Lite batteries.

Inverter Firmware Version

There is no minimum firmware requirement.

Communication

No communication is supported nor needed for Steca inverters.

Inverter Settings

The following settings are recommended for the inverter, sorted by inverter settings menu entries:

02 charge current: XXX A → where the formula is: (no. of batteries x 50 A) / no. of inverters. So, 50 A for a single inverter and battery, 100 A or lower for a single inverter and 2 batteries, etc.

05 battery type: USE

12 set-point to grid: 49 V

13 set-point to off-grid: 53 to 55 V

26 bulk CV charge voltage: 55.2 V

27 floating voltage: 54.8 V

29 low battery cut-off: 48.0 V

30 battery equalization: disabled

32 bulk CV duration: 150 minutes (this settings menu may not be available)

Battery Quantities

The following quantities of batteries are recommended (see section [General Battery Quantities](#) for details), while of course more batteries can be used.

Inverter Model	AC Phases	AC Power Cont.	Power Lite Minimum Battery Quantity
PLI 5000-48	1	5,000 W	3

Example for up to 2 Batteries

No bus bar required, and a single battery breaker is sufficient.

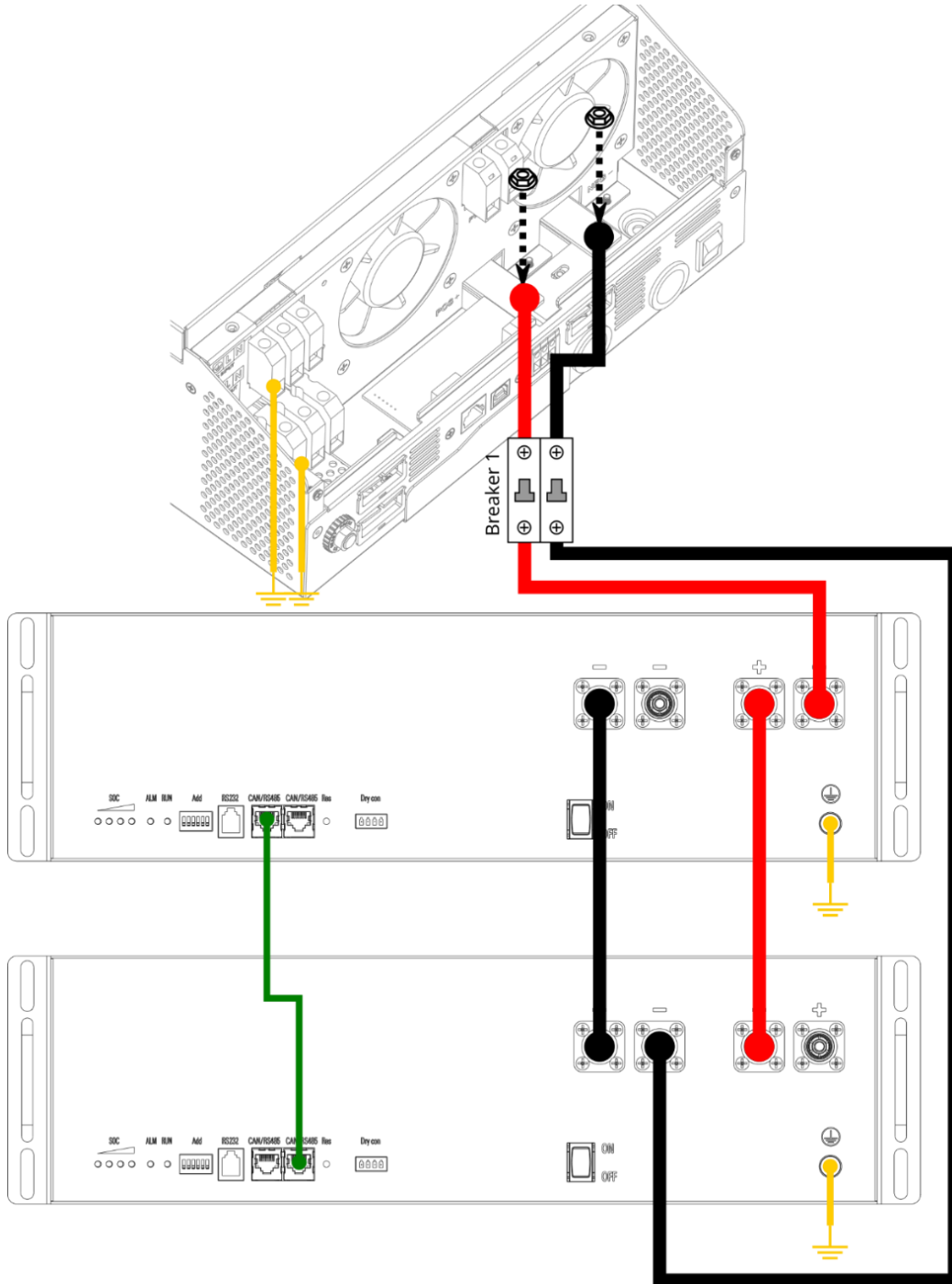

Example for 3 and more Batteries

Bus bar is required and a battery breaker per battery is recommended.

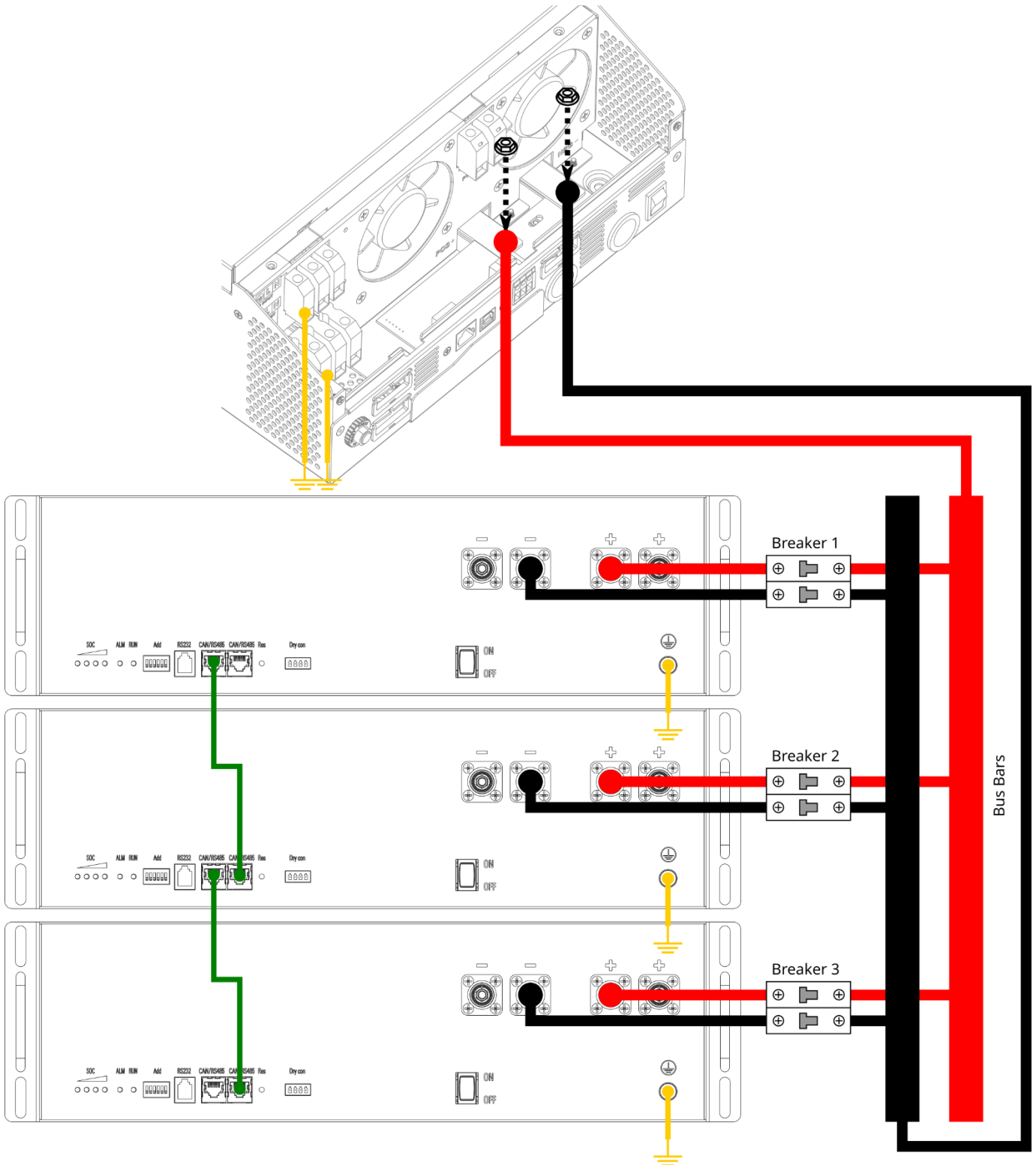

Studer Innotec

These examples apply to the following Studer Innotec products:

- next3
- Xtender series
- VarioTrack series
- VarioString series

and show L051100-A1 Power Lite batteries. See [Battery Communication](#) for details regarding -A, -B and -D Power Lite batteries.

Inverter, Charge Controller & Battery Firmware Version

The minimum firmware requirement is:

- Battery Firmware:
 - Power Lite L051100-A1 / -B / -D: LM-M01S-YZ109-21.Z0.17-220713.bin
 - Power Lite L051100-A (New): LM-M01S-YZ107-21.Z0.03-230105.bin
- Xcom-CAN (needed for VarioTrack, VarioString and Xtender): 1.6.70
- next3: 1.1.0.0

CAN Communication Pinout

next3

The next3 CAN communication port is labeled as follows, and the corresponding connector (rightmost picture) included with the inverter:

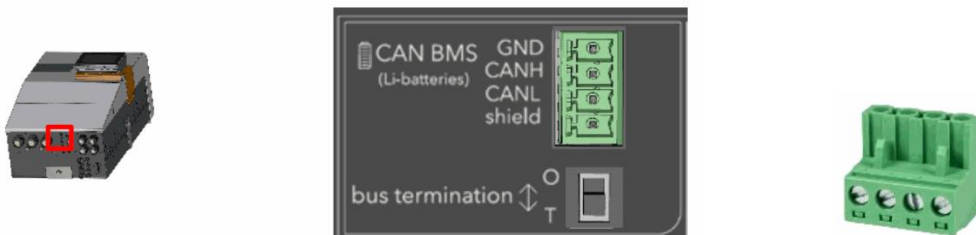

See section [Battery Communication](#) for the corresponding pins on the battery. Set the bus termination to “T” (terminated). Use a cable with an RJ45 connector on the battery end and wire the CANH, CANL and GND connectors to the corresponding connector pictured above for the inverter side.

Xtender

The Xtender products require an additional accessory, the Xcom-CAN, to communicate with the Power Lite battery. Inside the Xcom-CAN the jumpers (1) and DIP switches (2) must be set for UZ batteries before powering on the Xtender:



Jumper settings for Power Lite

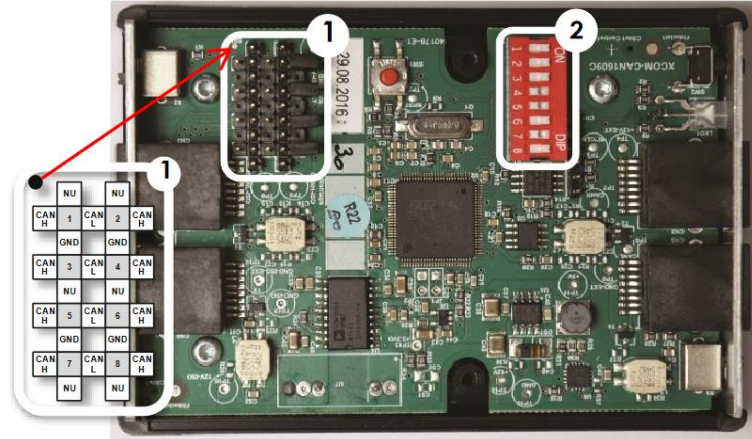

Xcom-CAN overview



DIP switch settings for Power Lite

Inverter Settings

Xtender

Once wired correctly and the batteries and inverter(s) are powered up, the batteries are detected automatically and the most relevant charge/discharge settings are set automatically.

next3

In the commissioning “Configuration wizard” in the battery section, enter the following settings:

Communicating battery → Yes

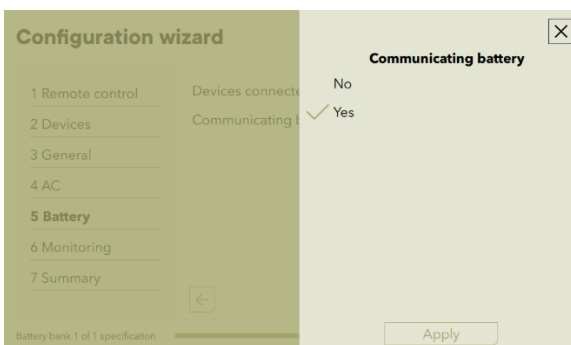

Manufacturer name → UZ Energy

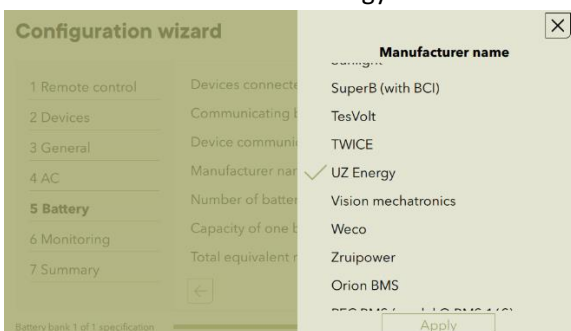



Enter the “Number of battery modules in parallel” and the “Capacity of one battery module”. For each Power lite battery, the capacity is always 100 Ah, so set this value for “Capacity of one battery module”. Then enter the number of batteries connected in parallel for “Number of battery modules in parallel”. So, in this example for two batteries, the “Total equivalent nominal capacity” is automatically calculated to be 100 Ah x 2 batteries = 200 Ah.

Configuration wizard ✕

1 Remote control	Devices connected to battery 1	2 devices
2 Devices	Communicating battery	Yes
3 General	Device communicating with batte...	NXT_3PH_012345
4 AC	Manufacturer name	UZ Energy
5 Battery	Number of battery modules in parallel	2
6 Monitoring	Capacity of one battery module	100 Ah
7 Summary	Total equivalent nominal capacity	200 Ah

Step 2 of 2

Battery bank 1 of 1 specification

Battery Quantities

The following quantities of batteries are recommended (see section [General Battery Quantities](#) for details), while of course more batteries can be used.

Charge Controller Model	Max. Current	Max. PV Power	Power Lite Recommended Battery Qty.
vt 40	40 A	2,500 W	1
vt 65	60 A	4,000 W	2
vt 80	75 A	5,000 W	2
vs 70	70 A	4,200 W	2
vs 120	120 A	7,000 W	3
Inverter Model	AC Phases	AC Power 30 Min.	Power Lite Recommended Battery Qty.
xts 1400-48	1	700~1,400 W	1
xtm 2600-48	1	2,600 W	2
xtm 4000-48	1	4,000 W	2
xth 6000-48	1	6,000 W	3
xth 8000-48	1	8,000 W	4
next3	3	15,000 W	6

Example for up to 2 Batteries (next3)

No bus bar required, and a single battery breaker is sufficient.

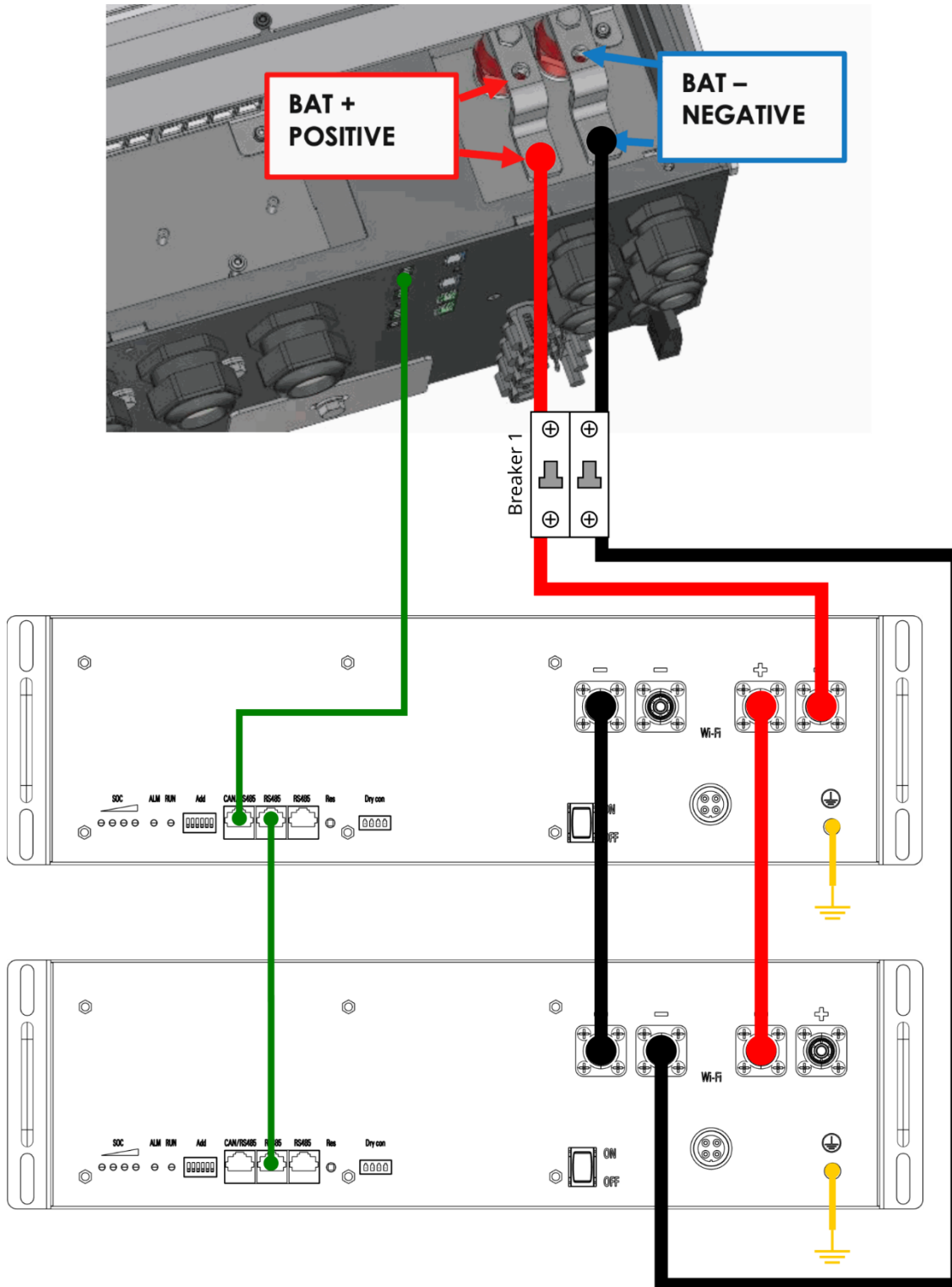

Example for 3 and more Batteries (next3)

Bus bar is required and a battery breaker per battery is recommended.

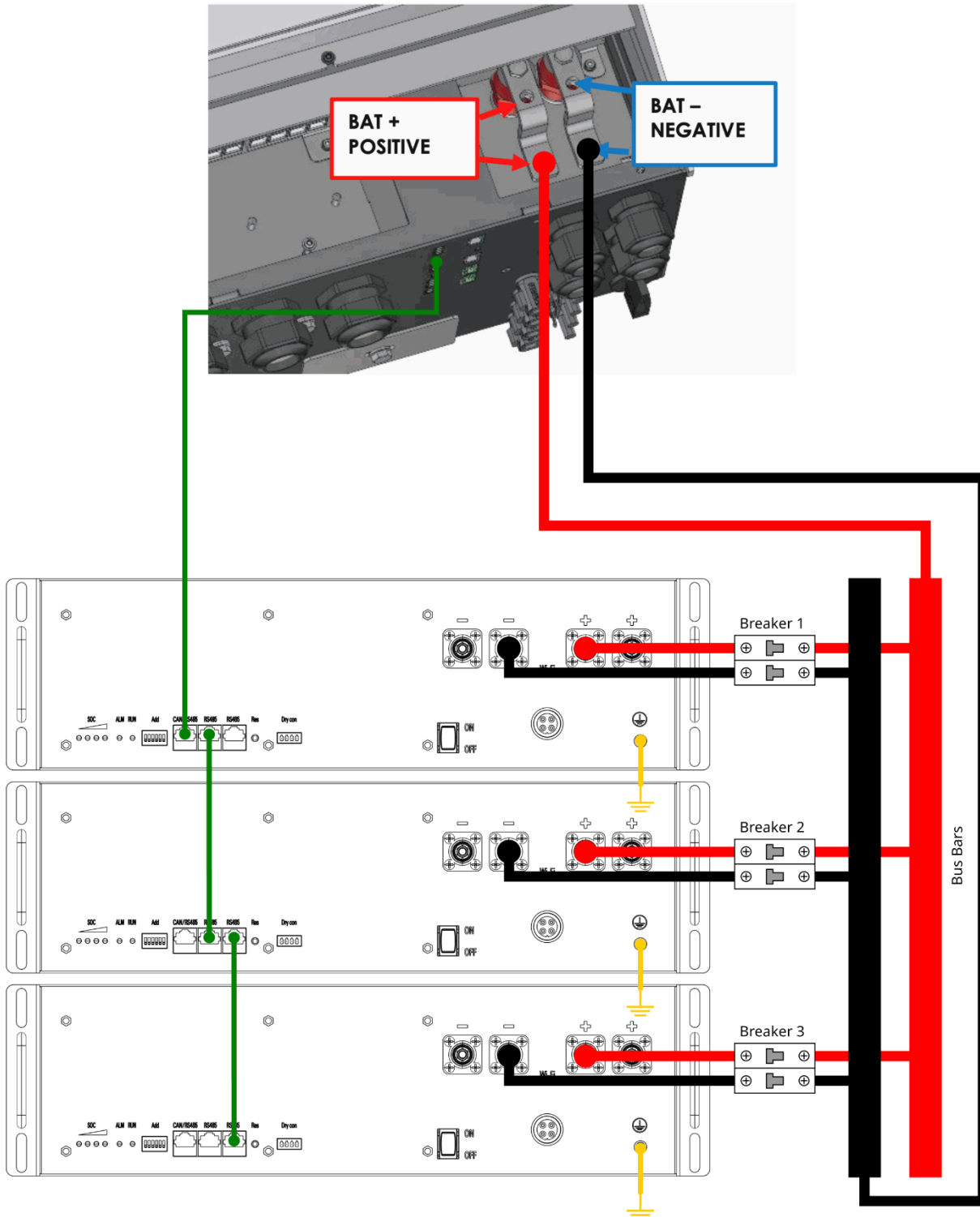

Victron Energy

These examples apply to the following Victron Energy products:

- GX products and any power conversion equipment that can interface with these products via VE.Bus

and L051100-A1 Power Lite batteries. Note that this is not compatible with Power Lite L051100-A batteries, only -A1 / -B and -D. See [Battery Communication](#) for details regarding -B and -D Power Lite batteries.

Battery Firmware Version

A battery firmware is available specifically for Victron inverters, see [Battery Firmware Overview](#). The minimum battery firmware requirement is:

- Power Lite L051100-A1 / -B / -D: LM-M01S-YZ109S-21.Z9.04-221124.bin

CAN Communication Pinout

GX have the following relevant CAN pinout on the BMS-Can or VE.Can terminal:

Pin	1	2	3	4	5	6	7	8
Function			GND				CAN-H	CAN-L

See section [Battery Communication](#) for the corresponding pins on the battery.

Some GX devices (such as the Cerbo GX), have multiple CAN ports. If your GX device has a BMS-Can port, this should be used. If your GX device ONLY has VE.Can ports, you will need to change the VE.Can port profile to CAN-bus BMS (500 kbit/s) for the battery (and then it cannot be used for other VE.Can devices).

Inverter Settings

The settings are automatically negotiated and communicated to other Victron devices via DVCC.

Battery Quantities

The following quantities of batteries are recommended (see section [General Battery Quantities](#) for details), while of course more batteries can be used.

Inverter Model	AC Phases	AC Power Cont.	Power Lite Recommended Battery Qty.
≤ 4000 W	1	≤ 4,000 W	2
5,000 ~ 7,000 W	1	5,000 ~ 7,000 W	3
> 7,000 W ~ 9,000 W	1	7,000 ~ 9,000 W	4
> 9,000 W ~ 11,000 W	1	9,000 ~ 11,000 W	5
> 11,000 W ~ 13,500 W	1	11,000 ~ 13,500 W	6
> 13,500 W ~ 15,000 W	1	13,500 ~ 15,000 W	7

Example for up to 2 Batteries

Example shows L051100-A1, Victron MultiPlus-II and Color Control GX. No bus bar required, and a single battery breaker is sufficient.

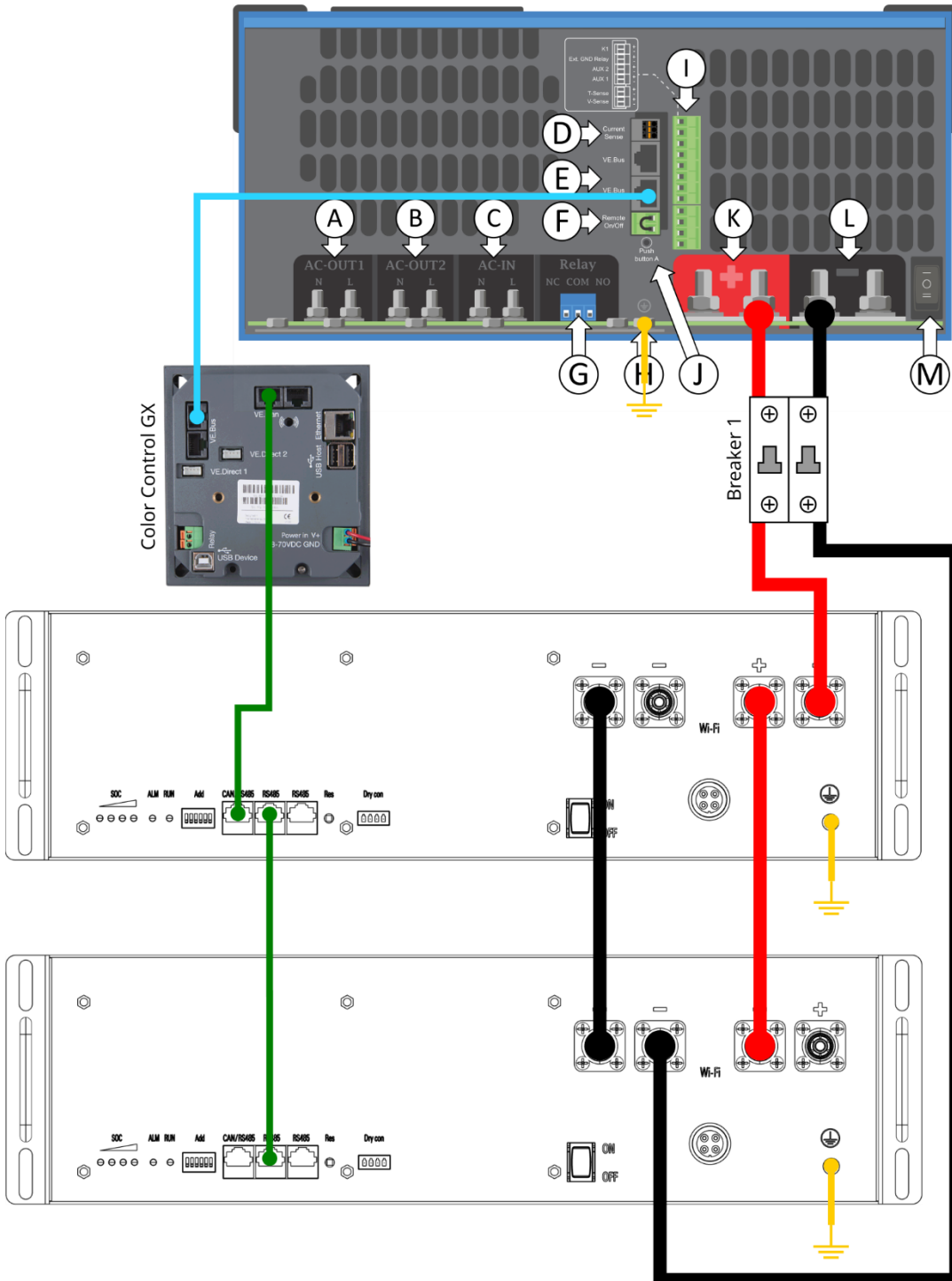

Example for 3 and more Batteries

Example shows L051100-A1, Victron MultiPlus-II and Color Control GX. Bus bar is required and a battery breaker per battery is recommended.

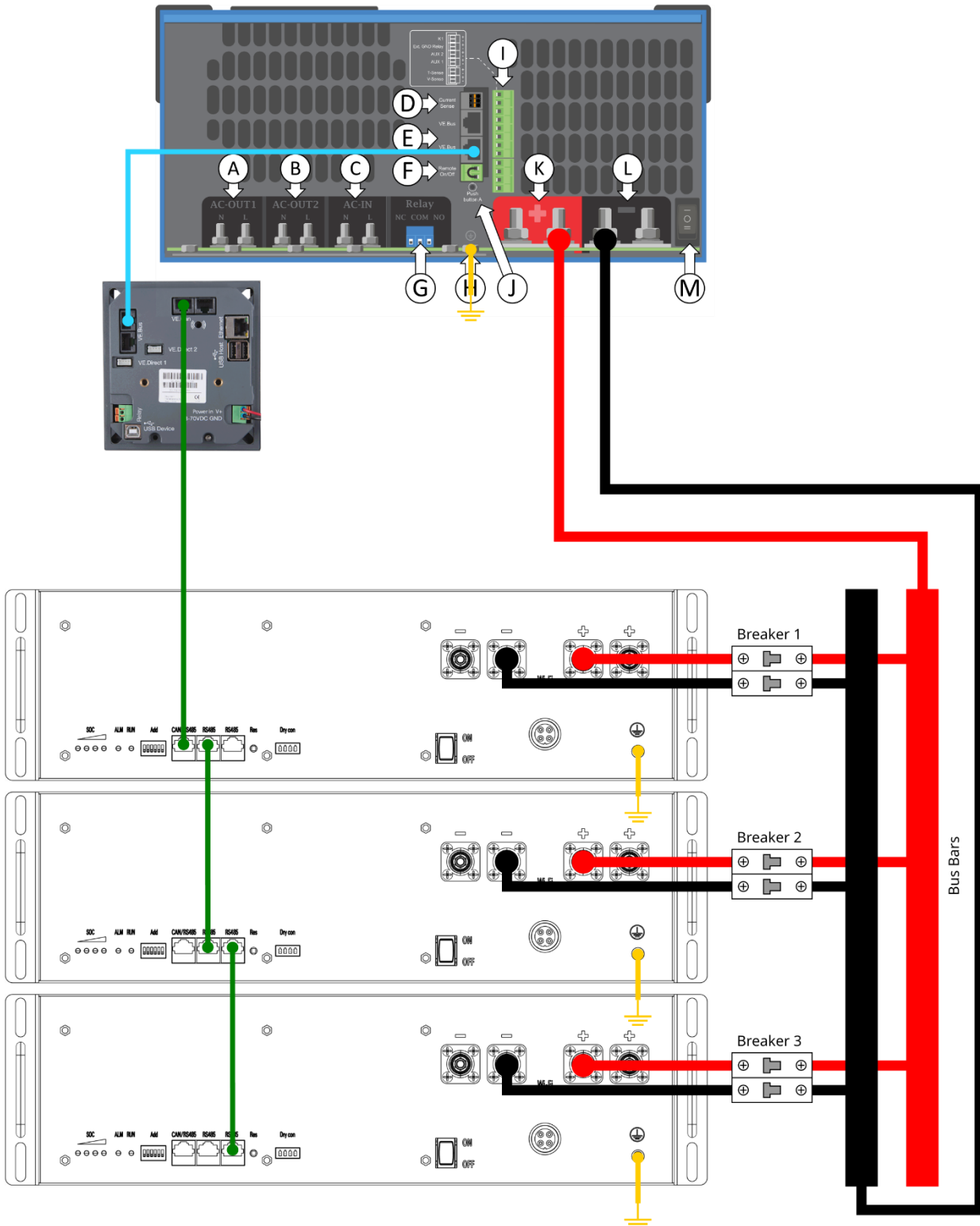

Voltronic Power (Open-Loop)

These examples apply to the following Voltronic inverters:

- All Axpert and InfiniSolar series inverters designed for 48 Vdc batteries

and show L051100-A Power Lite batteries. See [Battery Communication](#) for details regarding -A1, -B and -D Power Lite batteries.

Inverter Firmware Version

There is no minimum firmware requirement.

Communication

No communication is supported nor needed for Voltronic inverters in this open-loop configuration.

Inverter Settings

The following settings are recommended for the inverter, sorted by inverter settings menu entries:

02 charge current: XXX A → where the formula is: (no. of batteries x 50 A) / no. of inverters. So, 50 A for a single inverter and battery, 100 A or lower for a single inverter and 2 batteries, etc.

05 battery type: USE

12 set-point to grid: 49 V

13 set-point to off-grid: 53 to 55 V

26 bulk CV charge voltage: 55.2 V

27 floating voltage: 54.8 V

29 low battery cut-off: 48.0 V

30 battery equalization: disabled

32 bulk CV duration: 150 minutes (this settings menu may not be available)

Battery Quantities

The following quantities of batteries are recommended (see section [General Battery Quantities](#) for details), while of course more batteries can be used.

Inverter Model	AC Phases	AC Power Cont.	Power Lite Recommended Battery Qty.
≤ 4000 W	1	≤ 4,000 W	2
5,000 ~ 7,000 W	1	5,000 ~ 7,000 W	3
> 7,000 W ~ 9,000 W	1	7,000 ~ 9000 W	4

Example for up to 2 Batteries

No bus bar required, and a single battery breaker is sufficient.

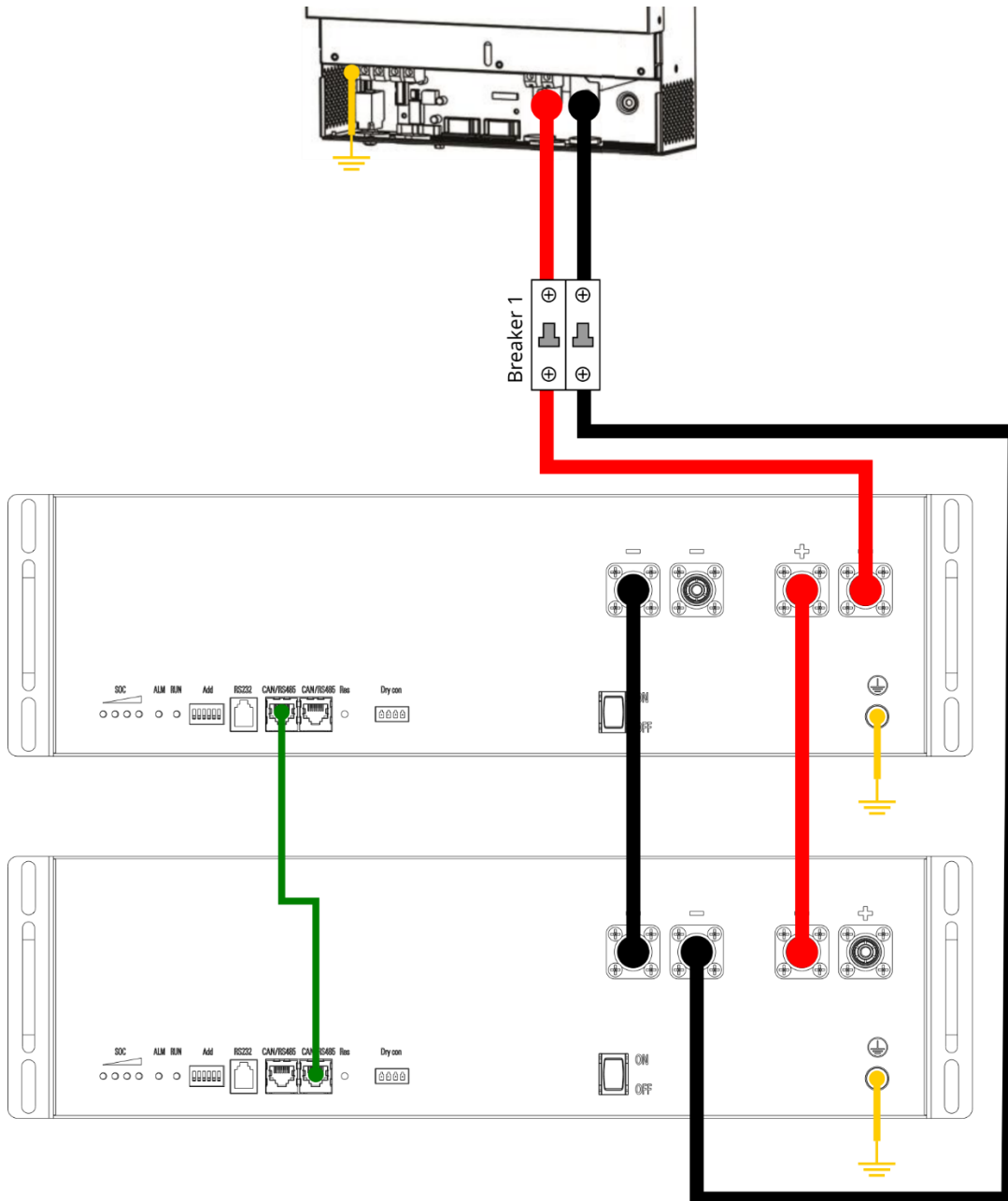

Example for 3 and more Batteries

Bus bar is required and a battery breaker per battery is recommended.

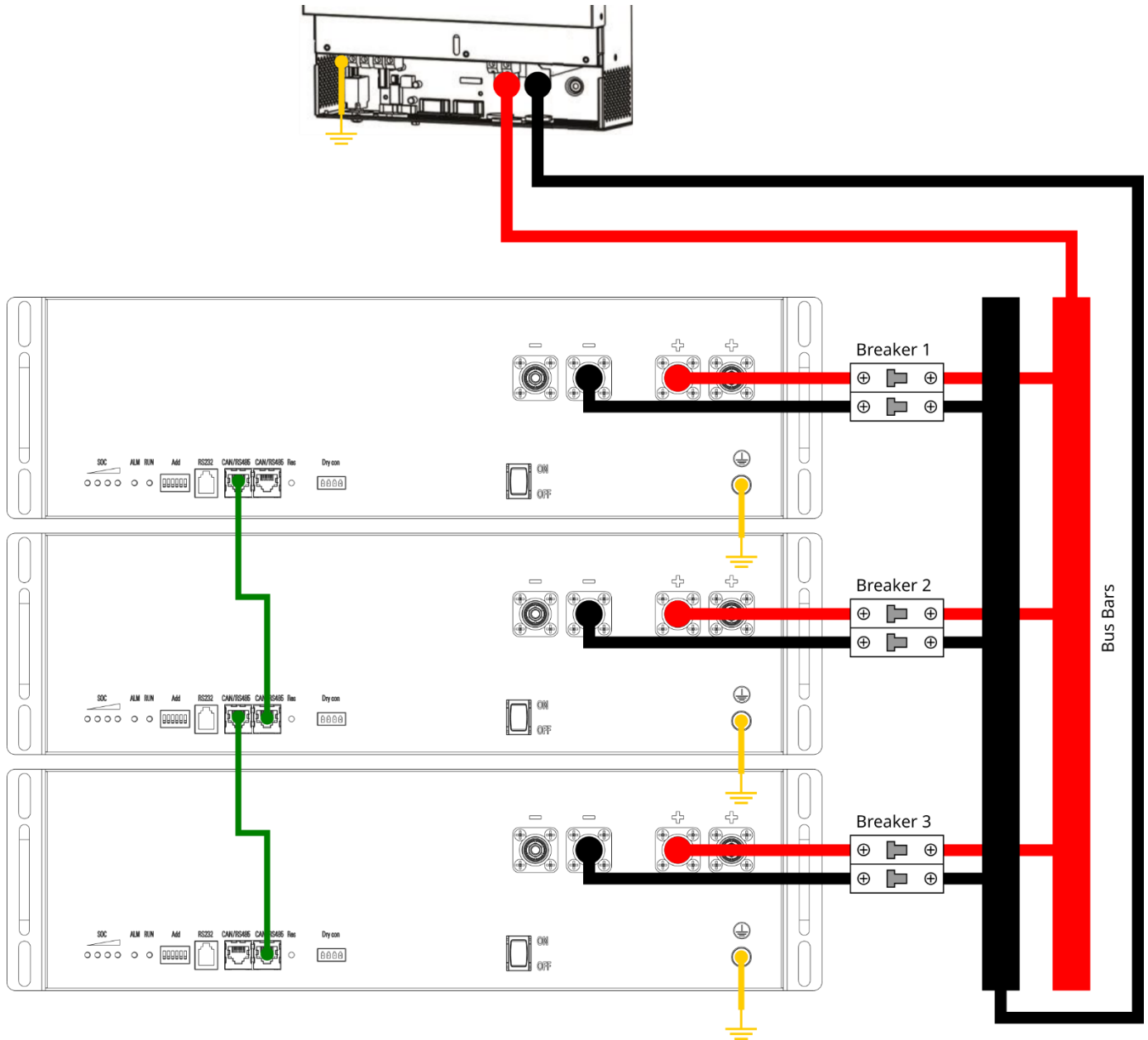



Voltronic Power (Closed-Loop)

These examples apply to the following Voltronic Power inverters (necessary inverter firmware may be pending completion at this time):

- Axpert King 5K (48 Vdc)
- Axpert King Rack 5K (48 Vdc)
- Axpert MAX (48 Vdc)
- Axpert VMIII (48 Vdc)
- Other Axpert inverters that have a CAN port

and show L051100-A1 Power Lite batteries in the example, but it also applies to -B and -D Power Lite batteries. When using -A Power Lite batteries, please use the methods in the section [Voltronic Power \(Open-Loop\)](#) instead.

Inverter Firmware Version

The minimum firmware requirement is:

- For inverter model: Axpert King 5K → available [here](#)
Firmware U1: 72.00
Firmware U2: 102.75
- For inverter model: Axpert King Rack 5K → available [here](#)
Firmware U1: 75.08
Firmware U2: 15.06
- Ensure that in the inverter settings menu 05 “CAN” is available as a battery type: . Select this battery type once all wiring is completed.

If this battery type is not available in your inverter, closed-loop communication is not possible, please use the methods in the section [Voltronic Power \(Open-Loop\)](#) instead. Alternatively, check with your dealer to see if there is a firmware update for the inverter available enabling “CAN” as the battery type.

Power Lite L051100-A1 Battery Firmware Version

Find the corresponding firmware in the section [Battery Firmware Overview](#).

CAN Communication Pinout

Voltronic Power inverters have the following relevant CAN pinout:

Pin	1	2	3	4	5	6	7	8
Function						CAN-H	CAN-L	

See section [Battery Communication](#) for the corresponding pins on the battery.

For the cables between the batteries and the RJ45 8P8C hub (see [Example for 3 and more Batteries](#)), standard straight CAT5 ethernet patch cables can be used without modification.

Inverter Settings

In the inverter settings menu 05 (battery type), set the battery type to “CAN”, shown as . If settings menu 01 is set

to “SBU”, the recommended settings for menu 12 is 50 V and for menu 13 is 55 V to fully utilise the battery capacity.

Battery Quantities

The following quantities of batteries are recommended (see section [General Battery Quantities](#) for details), while of course more batteries can be used. As the Axpert King series cannot limit battery discharge current and is designed for (partially) Off-Grid systems, we strongly recommend using at least the recommended battery quantity. Please find the recommended battery quantities in the section [Voltronic Power \(Open-Loop\)](#) → [Battery Quantities](#).

Example for 3 and more Batteries

Bus bar is required and a battery breaker per battery is recommended.

